

EC MINI-DOSE Monitor/Controller/Interface

Installation and Operating Instructions

Power requirements

This controller requires a 12V AC transformer plug pack rated at a minimum of 1 Amp (12VA).

Operation

The EC/CF Monitor/Controller may be used as a simple monitor or may have solenoid valves/ relays added to turn it into a complete control system capable of dosing A & B nutrients. It can be used to dose into the reservoir tank of a recirculating or batch run-to-waste system. It continually measures and displays the current EC and can operate up to three solenoid valves to replenish nutrients used by the plants.

A fail safe feature of the doser is that it will not dose if the measured value is below 1CF (0.1EC). This is to prevent over-dosing if the probe is inadvertently left out of the nutrient or if the probe cable is detached or broken.

Settings

Any of the settings listed below may be changed from the keypad. When a setting is saved, it is stored in permanent memory and will not be affected by loss of power.

Settings Available

<u>Program Mode</u>	<u>Setting</u>	<u>Explanation</u>
0	Display Conductivity	Displays current EC/CF value.
1	Set Point	The desired operating value.
2	Dose time (Secs)	The time in seconds that the solenoid valve will open in order to supply a dose of nutrient.
3	Dose interval (mins)	The minimum time that must elapse between doses. Allows time for mixing to occur.
4	Alarm Deviation	If the measured value deviates from the set-point by more than this value the alarm will be activated. The alarm will only sound if the alarm is switched ON and the deviation is exceeded for more than 4 minutes.
5	Alarm ON/OFF	Enables/Disables the alarm.
6	Dose Count	Displays how many times the system has dosed. This count is zeroed when

		power is removed. When this count reaches 255 it automatically returns to 0.
7	CAL Zero	Remove probe from the nutrient, rinse and dry. Then select this mode and press SET. Note: it is very unlikely that this calibration will ever be required as once it has been factory set it should never change.
8	CAL Slope	Dry probe; place in standard solution (27.64CF or 2.764EC). Allow at least 3 minutes for temperature stabilisation then select this mode and press SET. Recheck that reading is now 27 or 28CF (2.7-2.8 EC).

Setting the Controller

Press the SET key and hold it pressed. Then press either the UP or DOWN keys until the required program mode is displayed. This is signified by the  symbol together with the MODE number. Now release the SET key. The display blinks and shows the current setting. Press the UP or DOWN keys to obtain the required value then press SET and hold it pressed for about 1 second to store the new value. While the display is blinking, if no key is pressed for 20 seconds, the setting is cancelled and the display returns to mode 0.

It is preferable to select dose times and dose intervals that will minimise the risk of overdosing. In other words select relatively short dose times (3 secs for a very small system to about 10 secs for a medium/large system with intervals of say 10 minutes). The dose time should be adjusted so that each dose raises the conductivity by 1 to 2 CF (0.1 to 0.2 mS/cm). The dose interval should be sufficient to allow thorough mixing of the nutrient before it is possible for the next dose to occur. For maximum safety, increase the interval so that the dosing just keeps up with the system demand. Remember that as your plants grow, so will the nutrient uptake.

Of course, the above settings would take a very long time to initially dose the system so after dumping nutrient the interval can be changed to zero to get almost continuous dosing. Alternatively, manual override push-buttons can be fitted as shown below.

To Switch between EC and CF

Switch off power to the controller. Press and hold the SET button pressed. Switch on. Continue to hold the SET button pressed until the display comes on.

Installing the Controller

Install the controller in a dry, well-ventilated area preferably shaded from direct sunlight. The power socket should be supplied with 12V AC power. This should be rated at a minimum of 250mA when used as a monitor and 1Amp when used to drive solenoid valves. The outputs are current limited and supply a brief surge of current to pull in the solenoids and then a lower holding current. This prevents the solenoid valves from overheating.

The outputs may be used to control solenoid valves or a mains rated relay (with 12V DC coil) for controlling dosing pumps. If mains equipment is to be controlled a manufactured relay box (available from Autogrow Systems) should be used or else an electrician consulted.

The 0-5V DC output may be connected to an analogue-to-digital (ADC) interface attached to a personal computer, PLC or data-logger.

Two installation diagrams are provided.

Recirculating system installation

The first installation diagram is for a re-circulating system. A recirculating system has a continuously running pump that draws the nutrient rich water from the main reservoir and delivers it to the start of the grow gulleys or grow beds. These may be NFT gulleys or media beds.

In this system a small amount of fluid is tapped off from the output of the main circulating pump and allowed to flow through a sample pot. The EC sensor (and pH sensor if used) stands in this pot and continuously samples the slow flow of fluid through the pot. A sample pot is used in preference to placing the probes directly in the main reservoir in order to avoid fatigue of the probe cables due to the turbulence in the reservoir. Note that in addition to the bleed off to the sample pot a second tapping is used to spray water at an angle back over the surface of the tank. This breaks up the surface of the water and allows oxygen to be absorbed. It also provides a stirring action, which is critical for mixing in the nutrient stock solutions.

Position filters over an area which does not matter much if it gets wet. The reason for this is that when cleaning filters there is always some spillage. In particular, do NOT position them directly above the solenoid valves as these must be kept dry at all times.

When the system has been installed, partly fill the stock tanks with plain water. Then set up the controller and watch it function to ensure there are no leaks and that it is working correctly. Attend to all leaks before filling the nutrient tanks with concentrated nutrient stock. Nutrient stock is usually mixed so that it is 100 times the final concentration required. It is not important to get this exactly right as the doser will only add sufficient nutrient to obtain the correct EC (CF).

Run-to-waste system installation

The second diagram depicts a system in which the main pump is switched on periodically (by a timer or solar integrator) to pump the water from the reservoir tank to the grow beds. In this case the reservoir is usually called the batching tank as it is used to prepare or mix a "batch" of water ready for the next irrigation. It is generally accepted that batch mixing is far more accurate than in-line injection using venturis and/or injection pumps.

When the main pump draws water out of the tank, fresh make-up water will immediately start to flow into the tank and will dilute the mixture. Providing the flow of make up water is kept to a relatively slow flow this dilution can be kept to a minimum and if this dilution is detected the dosers will go some way to correct it. Of-course the flow must be sufficient to allow the tank to completely fill and be fully dosed up, in plenty of time for the next irrigation cycle.

A small auxiliary pump which runs continuously to circulate water through the sample pot and also to stir and aerate the water. Without this the sensors will sense only the static water in the sample and will not give a true reading for the water in the batching tank.. Stirring of the water is very important as the nutrient stock

solutions are laden with salts and tending to be denser than pure water, sink to the bottom where they can stay for some time.

Maintenance

Clean the end of the sensor probe regularly (weekly). To do this remove the shroud from the probe tip – if this is difficult to get off, insert a screwdriver shaft through two of the round side windows and use a firm twisting action. Clean the tip using a mild abrasive kitchen cleaner on an abrasive (ScotchBrite) cleaning pad. Suitable cleaners include Vim, Ajax, Jif, and Chemco. This cleaning process is required even if the probe “looks” clean.

After cleaning, rinse the probe and dry using a clean kitchen tissue. **DO NOT TOUCH THE ELECTRODES AS YOUR FINGERS MAY CARRY SMALL AMOUNTS OF OIL.** Replace the shroud fully – ENSURE THAT THE FACE OF THE PROBE IS FULLY WITHIN THE WINDOW AREA OF THE SHROUD. This will ensure that air bubbles cannot be trapped inside the shroud.

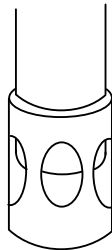

Correctly Fitted Shroud

Re-calibration

Calibration of the unit should be checked frequently (weekly).

Place the probe in 27.64 CF (2.764 EC) and leave it there for at least 3 minutes to allow for temperature compensation to take effect.

The controller should now read between 27 and 28 CF (2.7 and 2.8 EC). If not it may be re-calibrated as follows:

Press and hold the SET button. Press the UP or DOWN buttons until 08 is displayed. Then release both keys, allow the display to stabilise and then press and hold SET for 5 seconds to save the calibration. The display should now return to 27 or 28 CF (2.7 or 2.8 EC).

Trouble Shooting

- 1) If it is found that the unit will not re-calibrate then it is possible to return it to its factory settings. To do this remove power from the unit (i.e. switch off the power). Now hold all buttons pressed and switch on. Keep all buttons pressed until the display comes on. **THIS WILL CHANGE ALL SETTINGS BACK TO THEIR DEFAULT VALUES.** It should now be possible to re-calibrate the unit. Remember to change all settings back to suit your requirements.
- 2) **Overdosing.** This is usually caused by the probe not being in contact with the water – possibly due to:
 - An air bubble trapped at the tip of the probe – shroud not fully on.
 - Probe wires disconnected from the controller.
 - Flow to sample pot stopped.
 - Probe tip resting against container wall or bottom. Shroud missing.
 - Probe wires broken.
 - Setting for dose size too large.
 - Setting for dose interval too small.
- 3) **Measured value incorrect**
 - Probe end requires cleaning.

- Calibration required.

4) Measured value incorrect after calibration

- Allow longer time for temperature compensation.
- Probe end requires cleaning.
-

Conductivity Values

CROP	SUMMER		WINTER	
	CF	EC	CF	EC
Asparagus	12-16	1.2-1.6		
Babaco	16-24	1.6-2.4		
Beans	8-12	0.8-1.2	12-22	1.2-2.2
Beet	8-12	0.8-1.2	12-22	1.2-2.2
Broccoli	8-12	0.8-1.2	12-22	1.2-2.2
Cabbage	8-12	0.8-1.2	12-22	1.2-2.2
Callas	8-12	0.8-1.2	12-22	1.2-2.2
Carrot	8-12	0.8-1.2	12-22	1.2-2.2
Cauliflower	8-12	0.8-1.2	12-22	1.2-2.2
Celeriac	8-12	0.8-1.2	12-22	1.2-2.2
Celery	8-12	0.8-1.2	12-22	1.2-2.2
Chillies	24-28	2.4-2.8	24-35	2.4-3.5
Corn	8-12	0.8-1.2		
Cucumber	16-20	1.6-2.0	20-30	2.0-3.0
Ferns	8-12	0.8-1.2	12-22	1.2-2.2
Flor, Fennel	8-12	0.8-1.2	12-22	1.2-2.2
Flowers Annual	8-12	0.8-1.2	12-22	1.2-2.2
Flowers Indoor	8-12	0.8-1.2	12-22	1.2-2.2
Garlic	16-20	1.6-2.0		
Ginger	8-12	0.8-1.2		
Herbs	8-20	0.8-2.0	12-30	1.2-3.0
House Plants	8-12	0.8-1.2	12-22	1.2-2.2
Kale	8-12	0.8-1.2	12-22	1.2-2.2
Kumara	12-16	1.2-1.6		
Lettuce	8-12	0.8-1.2	10-16	1.0-1.6
Melons	16-20	1.6-2.0		
Okra	16-20	1.6-2.0		
Onion	16-20	1.6-2.0		
Parsley	12-16	1.2-1.6	16-20	1.6-2.0
Parsnip	8-12	0.8-1.2	12-18	1.2-1.8
Pawpaw	16-25	1.6-2.5	25-40	2.5-4.0
Peas	8-12	0.8-1.2	12-20	1.2-2.0
Peppers	24-28	2.4-2.8	28-35	2.8-3.5
Potatoes	24-28	2.4-2.8		
Pumpkins	16-20	1.6-2.0		
Radish	8-12	0.8-1.2	12-20	1.2-2.0
Roses	20-25	2.0-2.5	25-35	2.5-3.5
Sanderosa	16-20	1.6-2.0	20-40	2.0-4.0
Silver Beet	8-12	0.8-1.2	12-22	1.2-2.2
Spinach	8-12	0.8-1.2	12-22	1.2-2.2
Tomato (Garden Varieties)	24-28	2.4-2.8	28-40	2.8-4.0

Tomato (Commercial Hydro Varieties)	36-50	3.6-5.0	50-80	5.0-8.0
Turnip	12-16	1.2-1.6	18-24	1.8-2.4

Simple Installation

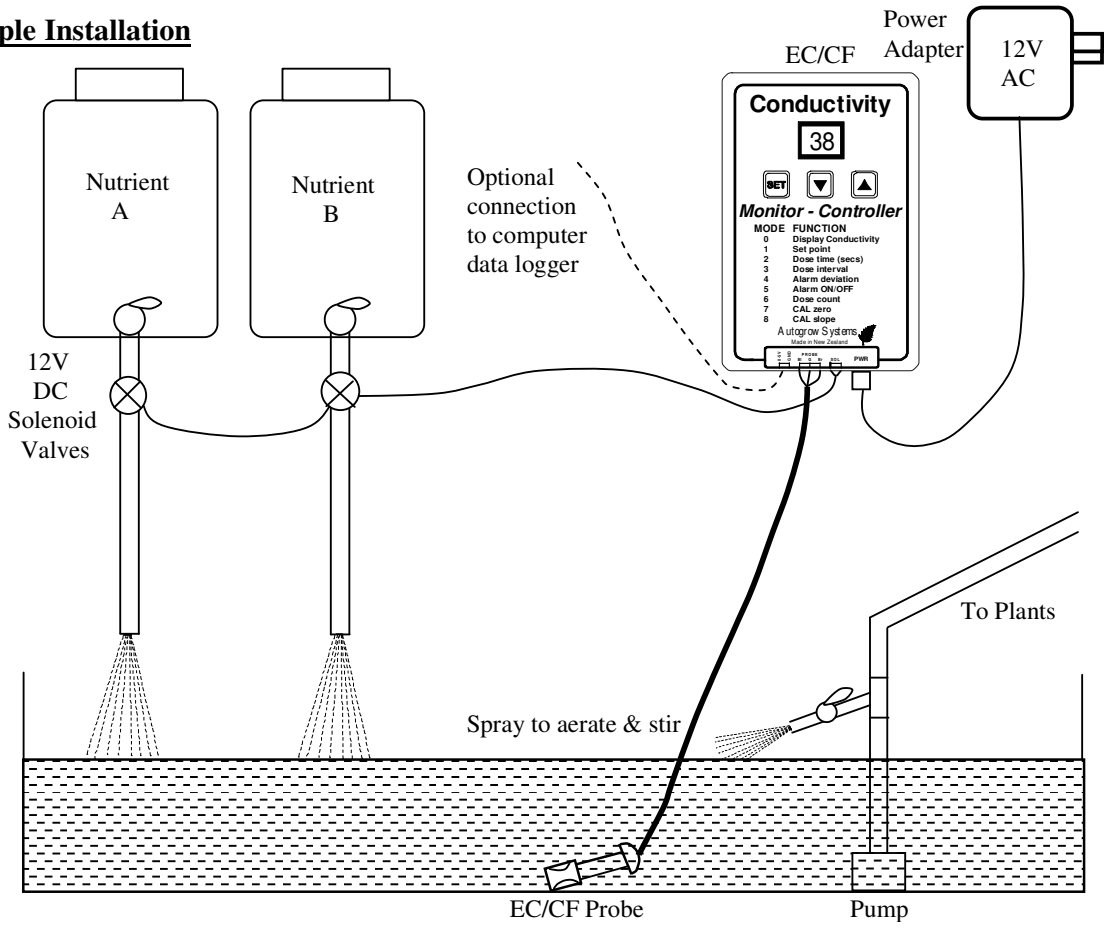

Preferred Installation

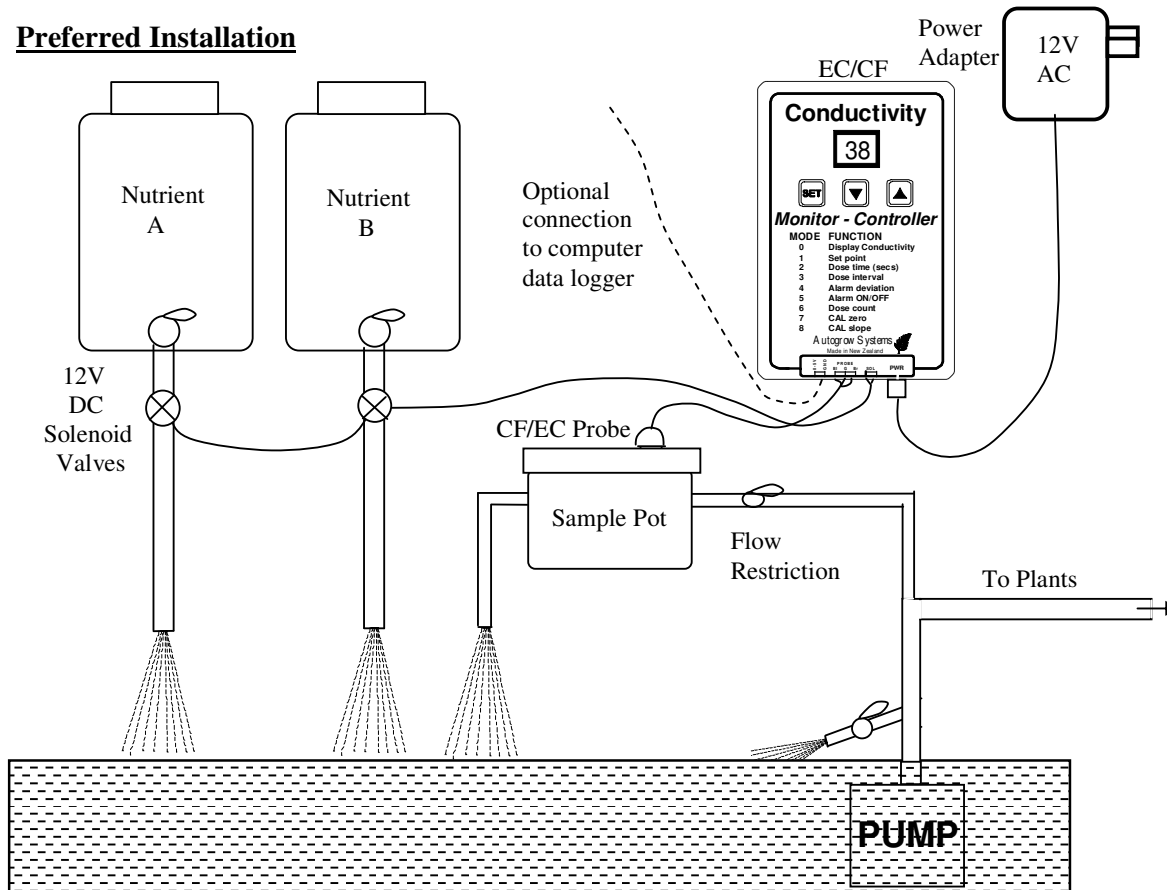

Diagram showing connection of manual override push button

