

NutriDose II (MK 3) Operator Manual

Computerized Nutrient Management Controller

- **On-demand Dosing**
- **Nutrient (Root Zone) Heating/Cooling**
- **Fertigation – two station**
- **Data logging**
- **Remote operation**

CONTENTS

1	Overview	3
2	Settings – the menu system	4
3	Continuously recirculating systems (NFT, DFT etc) And pulsed aeroponic systems	9
	3.1 Install controller and sample pot	9
	3.2 Dosing sub-system	9
	3.3 Selector switch setting	11
	3.4 Connect EC, pH and temp sensors	11
	3.5 Install solenoid valves or dosing pumps	12
	3.6 Install PC communications	12
	3.7 Set up dosing	12
	3.8 Sensor calibration	13
	- Example application – recirculating	14
4	Batch irrigation and Flood-drain	16
	4.1 Overview of batched irrigation	16
	4.2 Install controller and sample pot	17
	4.3 Dosing sub-system	17
	4.4 Selector switch settings	19
	4.5 Connect EC, pH and temp probes	19
	4.6 Install dosing solenoid valves or pumps	19
	4.7 Install fill solenoid valve	20
	4.8 Install pump relay	20
	4.9 Install zone solenoid valves	20
	4.10 Connect heater	21
	4.11 Install PC communications	21
	4.12 Set up dosing	21
	4.13 Sensor calibration	22
	4.14 Connection to AutoVent, EnviroSensor or solar integrator	22
	- example application – Batched irrigation	23
5	Connection diagrams	25
	5.1 Main circuit board	25
	5.2 Connectors	26
	5.3 Connection of sensors	27
	5.4 Connection of Dosing solenoids or pumps	27
	5.5 Data communications	28
	5.6 Connection to main pump	29
	5.7 Selector switch setting	30
6	Installation of Compugrow Software on the PC	32
	6.1 PC interface	32
	6.2 Communication address	32
	6.3 Terminator	33
	6.4 Installation of software	33
	6.5 Configuring the software	33
7	Maintenance	34
8	Fault finding	36
9	Warranty	36
10	Glossary of terms	37

1 Overview

The NutriDose II is a multi-purpose dosing/irrigation controller that is ideally suited to:-

- Recirculating systems such as NFT, DFT, raft systems etc
- Batched fertigation (two zones built-in)
- Flood-and-Drain (Ebb-Flow) systems
- Pulsed Aeroponic systems
- Blending run-off to a constant EC (see separate manual for this application)

The NutriDose II has a number of features that distinguish it from other systems including:-

- PC interface for remote setting, data logging and alarms
- High precision and accuracy in the measurement and control of pH and EC/CF*
- Separate day/night settings for EC (helps prevent tip burn!)
- Measures nutrient (root zone) temperature and controls nutrient or grow bed heating (or cooling)
- Dosing may be inhibited at high temperatures
- It has built-in outputs and controls to allow it to operate all aspects of a flood-drain table or a two-zone, batched irrigation system. These include control of tank fill, tank dose and stir, irrigate zone 1, irrigate zone 2, drain back period.
- When used for irrigation it has an input suitable for connection to a solar integrator so that in sunny weather irrigation frequency is automatically increased. Alternatively, an internal timer may be used to trigger irrigations at fixed intervals. Irrigation may be inhibited during night time in both cases.
- When used in continuously recirculating systems (NFT, DFT etc) it has two spare outputs that can be used for remote activation from the PC. For example, one output could be used to add a set amount of water to the reservoir tank to dilute the EC or to cool the nutrient and the other could be used to activate nutrient dumping. Alternatively, an output could be used to activate spraying or unlock an access gateway from the central PC.
- May be switched to display nutrient conductivity in either EC or CF units, temperature in deg C or deg F and dates in European or USA format.

The PC interface provides data logging and subsequent graphical display of EC, pH and nutrient temperature as well as the ability to remotely set the controller. It provides remote alarms at the PC (via its sound card) and also telephone alarms (via its MODEM) to a pager or cellular phone.

* Although the controller and software may be switched between EC(electrical conductivity) and CF (conductivity factor) we will use the abbreviation EC to represent both forms

Batched irrigation

In addition to the built-in controls for filling, batching, irrigating, the NutriDose II has many desirable features that other control systems lack. For example, if set to “irrigate during day-time only” and a trigger occurs during the night time, the NutriDose captures this trigger and holds it over to start an irrigation early the next day. The different EC (day) and EC(night) feature is an extremely useful feature for many growers as it can be helped to combat tip burn in many plants. Furthermore, the override timer provides additional security as it will force an irrigation if a solar trigger fails to arrive within a user-set maximum time. This protects against failures due to a leaf or other object falling on the solar sensor or a broken wire or connection from the solar integrator.

2 Settings

The controller is set up using two methods :-

1) the switches under the connection cover and 2) from the PC or front panel. The switch settings are mainly to do with the installation configuration and are discussed in the detailed installation instructions for each type of system. In this chapter we will look at the everyday settings made at the PC or from the controller front panel.

The way the controller is set up will depend on whether it is used for batched irrigation, flood and drain or for use in a continuously recirculating (NFT/DFT) system. Note that in either case, good use is made of the two time zones. The user can set the “dawn” and “dusk” times to suit their requirements and these do not have to relate to the actual hours of daylight. For example, you can choose to have ‘night time’ start at mid-afternoon if you so wish. The two time zones allow a different EC (CF) to be set for day and night or to prevent (or allow) irrigations during the night.

2.1 The Menu system (from the controller front panel)

The menus are arranged in two levels. At the top level the ‘main menu’ shows the major groupings of settings and beneath that the sub-menus show the detail. To move from a main menu item down to its sub-menu, press the ‘enter key’ (up arrow). When in a sub-menu, just press the ‘exit’ (save) key to exit back up to the main menu. Alternatively, just wait without pressing any keys and the controller will automatically return to mode 0 after about 20 seconds. If this happens any changes made will be discarded. Note that the sub-menu items start with the same number as its main menu parent. Remember, that after a setting has been changed, you must press the save button to make the change permanent.

MODE	FUNCTION
A	Display EC, pH and Temperature
B	Display Air Temperature, RH and solar
C	Display Solar Integration and Trigger value
D	Irrigation status screen

Main Menu

M1	OVERRIDES
M2	SET POINTS
M3	CALIBRATION
M4	TIME/DATE
M5	ALARMS
M6	SYSTEM
M7	BLENDER

Sub menu from M1 - Overrides

M10	Dose Enable/Disable
M11	Dose EC Now
M12	Dose pH Now
M13	Irrigation Enable
M14	Enable Solar Integration (Only if ES or AV used)
M15	Z1 Enable/Disable (Z1 = irrigation Zone 1)
M16	Z2 Enable/Disable
M17	Irrigate Z1 now
M18	Irrigate Z2 now
M19	Trigger irrigation cycle now
M1A	Fill Now
M1B	Stir Now
M1C	Temperature control enable/disable

Sub menu from M2 - Setpoints

M20	EC Setpoint (Day)
M21	EC Setpoint (Night)
M22	pH Setpoint
M23	pH raise/lower
M24	Temperature Setpoint
M25	EC Dose Time
M26	pH Dose Time
M27	Dose Interval
M28	Fill time
M29	Maximum stir/dose time (Irrigation mode only)
M2A	Z1 Irrigation time
M2B	Z2 Irrigation time
M2C	Solar Integrator Trigger
M2D	Override time (maximum time between irrigations)
M2E	Irrigate Day only / Day & Night
M2F	Drain Time

Sub menu from M3 - Calibrate

M30	Cal pH7
M31	Cal pH4
M32	Cal EC

Sub menu from M4 -Time and Date

M40	Display Date and Time
M41	Clock Set Minutes
M42	Clock Set Hours
M43	Clock Set Days
M44	Clock Set Months
M45	Clock Set Year
M46	Dawn Time
M47	Dusk Time

Sub menu from M5 - Alarms

M50	Alarm ON/OFF
M51	Alarm EC limits MAX
M52	Alarm EC limits MIN
M53	Alarm pH limits MAX
M54	Alarm pH limits MIN
M55	Alarm Temp limit MAX
M56	Alarm Temp limit MIN
M57	Alarm Detent (Time until alarm sounds after fault detected)

Sub menu from M6 - System

M60	A/B balance for nutrient dosing
M61	Irrigation trigger source
M62	Address (all units must be set to a different address)
M63	Uncalibrated readings for EC, pH and Temp (factory settings)
M64	Inside box temp (hidden)
M65	Calibrate RH (from enviro sensor)
M66	Calibrate Solar (from enviro sensor)
M67	Only dose when nutrient temperature below limit

Sub menu from M7 - Blending

M70	Start percentage
M71	Blend using (choose EC feedback)
M72	Blend detent (to allow time between adjustment and reading)

Most of the settings are reasonably self explanatory and we will review them only briefly.

Mode A, B and C - Readings

In these modes reading of the measured variables are displayed. Whenever the “save” (exit) key is pressed the controller reverts to display mode A.

Mode D – Irrigation status

This mode indicates the current irrigation status. For example, it might say “filling tank”, “waiting for trigger”, “irrigating zone 1”, “irrigating zone 2”, “draining” etc. This screen is most useful in irrigated and flood and drain type systems.

Mode 1 - Overrides

The items under mode 1 are all associated with either disabling/enabling the dosing/irrigation or else forcing an immediate dose or irrigation. Note that when forced on, the output will stay on for the normal period of time that has been set (under setpoints). Note that you can only enable “Solar Integration” if you have a Enviro Sensor connected to RS485 bus A of the NutriDose II.

Mode 2 – Set Points

This is where most of the settings are stored. For example, the desired EC, pH and temperature setpoints together with the associated dose times (ie the time in seconds that the dose will last for). Note that both EC and pH share a dose interval (the minimum time that the controller will wait between one dose and the next). This interval allows time for the previous dose to mix with the water in the main tank before it checks to see if a further dose is needed.

The irrigation and fill times are also set here. The fill time should be more than sufficient for the tank to fully fill. The tank will not overflow as this will be prevented by a float valve.

Mode 3 – Calibrate.

All measured variables may be calibrated here. Note that when calibrating pH, always start by calibrating at pH 7 and then move on to pH 4 (after rinsing the probe in water). The EC can be calibrated at any value so you should obtain a standard test solution close to the value that you will be growing at. Most laboratories can supply EC test solution to any value requested.

Before calibrating EC ensure that the probe face is absolutely clean and that the shroud (if used) is replaced fully. If a shroud is not used then the probe must be held so that its face is suspended in mid-solution. Also, with any of the calibrations, allow the probe to stand in the test solution for as long as possible (at least 10 minutes) before calibrating. This is to allow the temperature compensation to fully adjust and for any readings to completely settle.

Mode 4 Time and Date

The clock-calendar is used to “time and date stamp” each sample for logging to the PC. It is also used to determine the time zone (day/night) changes for dosing and irrigation. The clock will need correcting from time-to-time. In addition the dusk and dawn times will need adjustment to compensate for the seasonal changes. Note that the clock display can be changed between mm/dd/yy and dd/mm/yy formats

The dusk and dawn time can be set to any values to define the two time zones. These do NOT have to be aligned to the true dawn and dusk.

Mode 5 - Alarms

This sub-menu allows you to set the upper and lower limits for all variables. **Note that the limits for EC and pH do not apply during the fill- wait-dose/stir times when “irrigation mode” is selected and only come into effect when the dose/stir is complete and during irrigation.** The purpose of the “alarm detent” is to allow a little time after a fault is detected before the alarm sounds. This is to reduce false

triggering from events such as a passing bubble in the water lowering the EC for example. A good starting point for this is between two and five minutes.

Mode 6 – System

In this section is the A/B balance setting. This allows you to vary the B nutrient dose time in relation to the A dose time. Normally this is set at 100% so that the B dose is the same as the A. If it is found that B tank is emptying slower than the A tank then one could try a setting of B=105% of A to make B dose for a little longer than A. Next comes the selection of the irrigation trigger source. This can be from either an AutoVent 2 or 3 controller, an Environment Sensor unit or even a simple solar integrator which provides a contact closure. If used for fertigation, one or other source must be selected or else the NutriDose will only trigger on timer override. Under system you need to set the address for the controller. This is the address number that is sent out by the PC when it wants to communicate with the controller. The same number must be entered in the PC software when this is set up. If you have more than one controller or monitor connected to the PC then each one must have a different address set at the unit and at the PC.

If an enviro sensor box with solar sensor is connected direct to the Nutridose for the purpose of triggering irrigations then it is possible in M65 and M66 to adjust the calibrations of the RH and solar sensors.

Also found here is a setting useful for high temperature situations. The “Only dose when nutrient (grow bed) temperature is below limit” setting allows the user to enter a temperature above which dosing will be inhibited.

Setting from the PC

Similar settings are available at the PC but in a much more user-friendly way. Just go into the ‘Readings and settings’ tab for the Nutridose that you want to set and you will find all of the above settings. To change a setting, click into the white box and type in the required value. Remember, to click on “save” at the bottom of the screen to send the new settings to the controller. When working at the PC, the refresh button at the top of the screen may be used to get an immediate update of information from the controller.

To correct the controllers clock calendar or set the dawn and dusk times, go into the “time” tab. This tab has a convenient button that allows you to make the controllers time and date the same as the PC time and date with a single click of the mouse. This is the easiest and best way of setting the controllers clock-calendar. To avoid confusion, ensure that both the controller and PC are set to display the date in the same format ie either mm:dd:yy or dd:mm:yy. On the PC, this is set from the “control panel” facility. At the controller the date format is selected by moving one of the selector switches which are found just inside the right hand side cover.

For installation and initial configuration of the software please refer to chapter 6

3 Continuously recirculating systems (NFT, DFT etc) and pulsed aeroponic systems

Pulsed aeroponic system will be set exactly like a recirculating system except that selector switch 8 will be ON and the Z1 output can then be used to operate the pump for short pulses of misting

3.1 Install the controller and sample pot

IMPORTANT:

- 1) **The voltage rating of the controller must match with your mains power supply voltage**
- 2) **The NutriDose must be installed (and stored) in a shaded, cool, dry, well ventilated position.**

This may be inside a greenhouse which is fully controlled so that the relative humidity does not regularly exceed 90%. For uncontrolled greenhouses, propagation houses, or other high humidity situations it must be installed in a plant room next to the greenhouse which itself is cool, dry, shaded from direct sun and well ventilated. It must never be left in full sunlight or in very hot conditions such as in an automobile. If installed within a greenhouse this normally means that a special shade/drip cover is provided as shown below. This is important as the surface temperatures of items in a greenhouse in summer, in full sun, may easily exceed 60 deg C (140 deg F). If this is allowed to happen the warranty is voided.

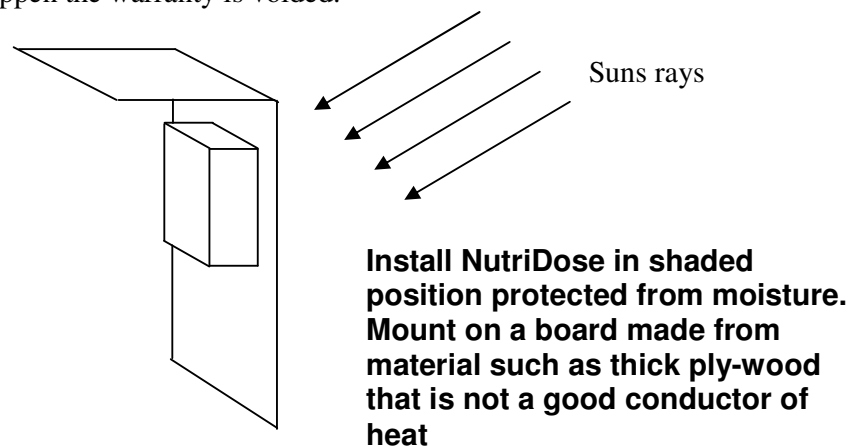

Position the sample pot within close reach of the controller but not where the controller is liable to get splashed if the sample pot overflows etc. Ensure that the leads to the sensors will easily reach between the controller and the sample point.

3.2 Dosing sub-system

Dosing can be done in a number of ways. Where the main tank is underground a simple gravity fed system using solenoid valves may be used. Having the main reservoir tank below ground level has a number of additional advantages such as helping to keep the nutrient water cool during summer as well as saving floor space. In recirculating systems it is also convenient to have the tank under floor so that the return water can flow back under gravity.

In this example, it is assumed that water is supplied under pressure from either the town water supply or from a pressure activated pump which supplies water from a bore (well) or from a storage tank.

It is good practice to either limit the size of the stock tanks or use small “day tanks” that are filled from the larger stock tanks at the start of each day. This will limit damage to the crop in the event of a gear or setting failure. Using pumps for the daily filling operation will also stir the main stock tanks and prevent stratification (heavy salts sinking to the bottom). The filling operation can be automated by using a simple timer switch to run the filling pumps each morning.

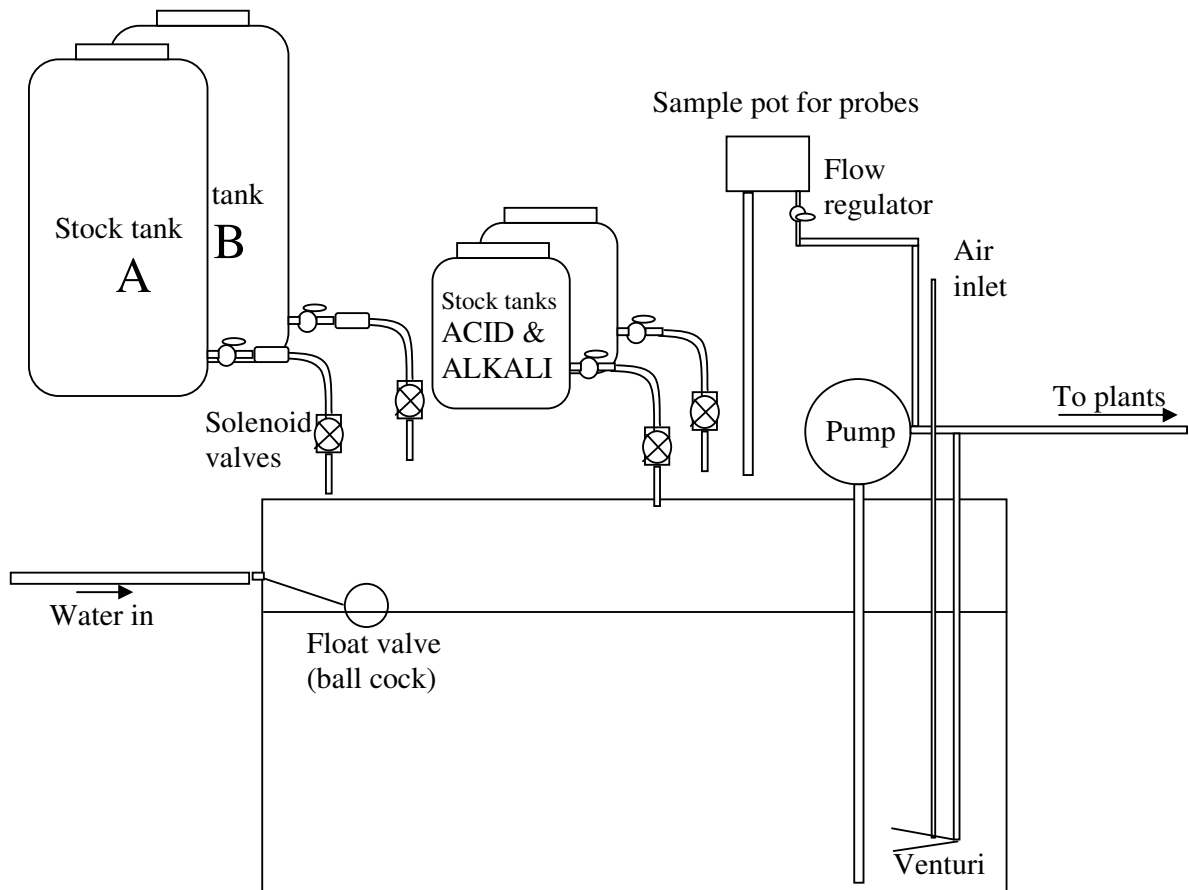

Simple gravity feed dosing system

To ensure an equal dose from the A and B stock tanks it is important that both A and B filters are clean and that the pipes are of equal length and are not kinked or otherwise restricted. To achieve equal dose sizes it is also important to position both A and B tanks and also the A & B solenoid valves or pumps at the same height.

In situations where the main tank is not below ground level, peristaltic pumps may be used to deliver the nutrient from the stock tanks or day tanks up into main reservoir tank. Many growers prefer the pump option as there is slightly less chance of overdosing in the event of a solenoid becoming jammed open. However, with regular maintenance this should never happen.

Note also, that during dosing, the pump must keep the nutrient solution flowing through the sample pot and the nutrient water in the main tank must be thoroughly mixed. This can be done by running the main pump as shown in the diagram. Note the use of a venturi to aerate and stir the main tank. This is highly recommended.

3.3 Set selector switch (located under side cover)

Switch OFF the “Irrigation” and the “Main Pump on to stir” switches
 The AutoVent slave switch should be set to ON if this NutriDose is to access environment information from an AutoVent controller
 The remaining switches can be set to suit your personal preference.

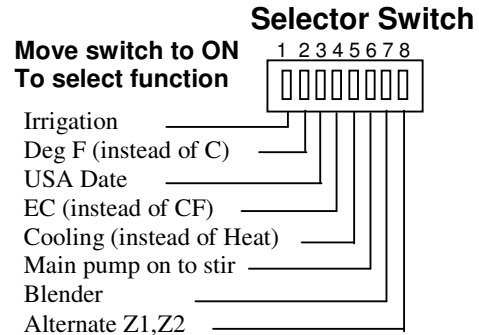

Switch 8 may be set to alternately irrigate Z1 and Z2. This allows a small pump (and hence less electricity) to be used in a large recirculating system. The output is then directed alternately to the two areas by means of solenoid valves. Usually the water is directed to each area for around 10 minutes at a time.

3.4 Connect the EC probe, pH electrode and temperature sensor

The pH electrode simply connects to the BNC connector on the front panel. The EC probe and temperature sensor are connected to connector 1 (the leftmost connector) which is located under the cover on the right hand side of the controller.

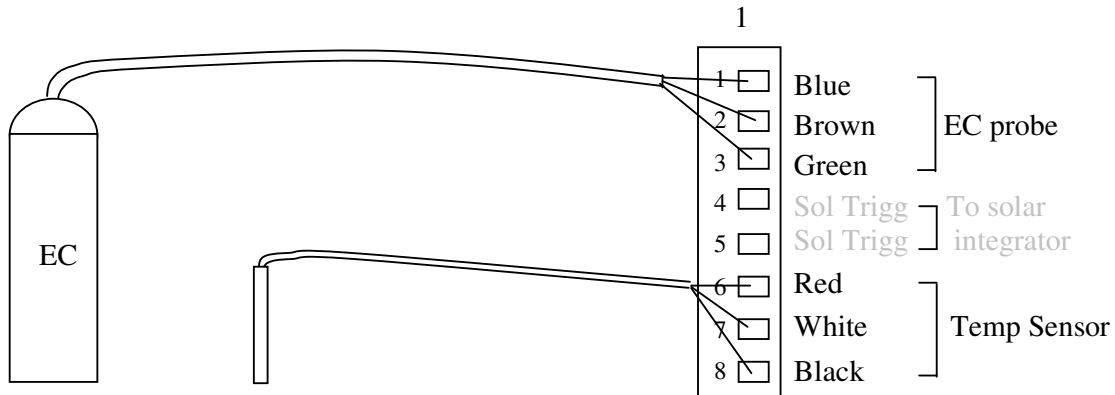

Connection of EC probe and temperature sensor

3.5 Install and connect the dosing solenoids or peristaltic pumps

24VAC pump relays
or solenoid valves

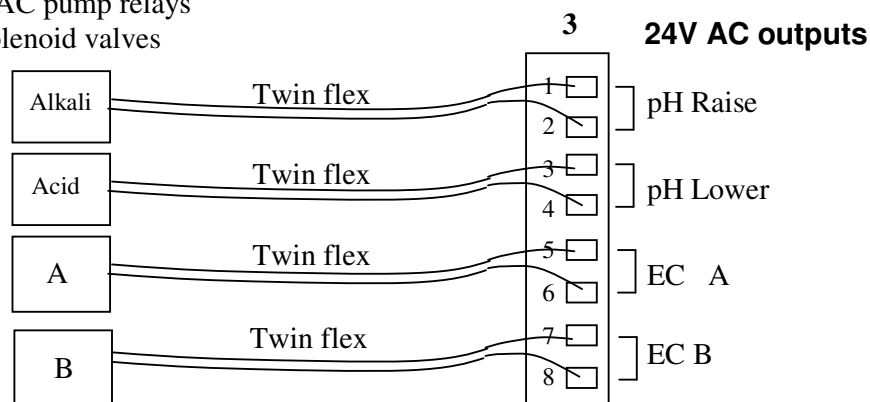

Connection of dosing pump relays or solenoid valves

3.6 PC communications.

Connect the PC data communications cable and install the Compugrow software as shown in chapter 6

3.7 Set up the dosing set-points.

Set the EC (day time) and EC (night time) – It is common to set the day setpoint a little lower than the night setpoint so that the plants can transpire freely during the heat of the day. For this to be effective the reservoir tank must not be too large so that the EC will fall due to the plants feeding, in time for the hottest part of the day. Set the pH set point and also specify if pH lower or pH raise is required. Then set the dose times for both EC and pH. The dose time should be sufficient to cause a change in EC (after mixing) of 0.1 to 0.2 mS/cm (1 to 2 CF) and a change in pH of 0.2pH after mixing. The dose interval should be set to a sufficient time for each dose to fully mix with the water in the tank. If the dose sizes are too small, the controller will make many small doses in a day and the solenoid valves or pumps will wear out quicker than if a larger dose size is selected. Note that only good quality, direct acting, chemically resistant solenoid valves should be used.

When first installed and set-up it is always a good idea to first fill the stock tanks (A& B fertilizer, acid and alkali) with water and observe the dosing operation for a while. This will also give you an opportunity to test for leaks. Test the dosing outputs by forcing them on and off from the PC “Readings and Settings” tab or from the controller “overrides” sub menu. Also watch them occur automatically.

When everything has been checked out, fill the A & B drums with the fertiliser mix as directed and stir thoroughly until fully dissolved. In larger systems it is common to use small pumps to circulate and stir the stock tanks to mix them thoroughly. These pumps can also be used to fill the smaller “day tanks”. Next fill the acid and alkali

tanks as follows:- First add the water to each tank and then add acid and alkali to the water to achieve a concentration of about 1:50 (2%); stir the mixture as the heavy acid will sink to the bottom. Note that if strong acid/alkali is dosed into the nutrient solution it can cause a localized chemical reaction, which will gradually cause the composition of the nutrient to change.

3.8 Sensor Calibration

The next job is to calibrate the controller for pH and EC. When calibrating it is a good idea to disable dosing first but remember to re-enable it when you have finished. To disable it press the mode key to get to the “Overrides” menu item, press enter (up arrow) to enter this sub-menu. The first menu item is dose enable so press the down arrow to set this OFF and then press save.

Calibrate pH

Connect the pH electrode to the plug connector on the front of the unit. Place the electrode in the pH 7 buffer solution and allow it to stand for 10 minutes. Now press the mode button to get to the “calibrate” menu item. Press enter (the up arrow) briefly to enter the calibrate sub-menu. Now press the up or down arrows until the reading is exactly 7.00pH. Press save.

Rinse the electrode in water, then place in pH 4 buffer solution. Wait for 10 minutes and then press the mode button to get to “calibrate” on the menu. Now briefly press enter (up arrow) to enter the submenu and **now press the Mode button again to get to cal pH 4**. Now, press the up and down buttons to get the reading to be exactly 4.00pH and press save. Recheck by placing the pH electrode back into the pH 7 buffer.

Calibrate EC

Clean the face of the EC probe using a clean nylon kitchen scourer such as a “ScotchBrite” together with a mild abrasive cleaner such as “Jif”, rinse in water and place in the EC standard solution. Allow ten minutes for the temperature compensation to take effect. Now press “mode” to move down to “calibrate”, press “enter” and then press the mode key again to get to the CAL EC (CF) mode. Now press the up and/or down arrows to get the reading to be exactly the same as the value of the standard solution (usually 27.7 CF or 2.77 EC). Press save.

Note: For highest accuracy, use a standard solution which is as close as possible to your working value and renew the standard solution at regular intervals (3 monthly) .

Remember to re-enable dosing when you have finished calibration.

Example Application-

Recirculating system with two level tank system

In a simple recirculating system, there is no need for a solar integrated trigger or for the NutriDose to control the tank filling or irrigating. This leaves spare outputs that can be used for any purpose desired. The diagram below gives some suggestions for the remote control of water level.

One possibility is to use the spare outputs to allow more total control of the mixing tank. For example, one output (FILL) could be used to add a quantity of water to the mixing tank. This could be done in the heat of the day to 1) lower the mixing tank temperature and 2) immediately reduce the EC. Both of these measures are useful for the grower and to be able to do them from a distance is a real plus (eg from the office, home or even further afield by using remote access software (eg PCAnywhere))

The other use is for remote dumping of the mixing tank. By setting the valve time to dump say 25% of the tank, this could be done in stages. If the dumped nutrient is led away to perform some useful purpose (eg irrigate/feed some outdoor plants) and 1/4 of the tank was dumped every week, the outdoor plants would grow well and build up of unwanted salts in the mixing tank would be avoided.

In fact, the two spare outputs could be used for all manner of remote control tasks such as unlocking an access gateway, feeding livestock etc.

NutriDose II application data

1. Recirculating system with remote water level control

Water level can be increased to "high level" at the NutriDose II controller or at the PC (or even by telephone using remote software). The increase in water level each time this is done is presettable by the user and is limited by the float valve to prevent overflowing. Water can be added to get a rapid drop in EC or to cool down a tank that is getting too warm. Water can also be dumped by remote command.

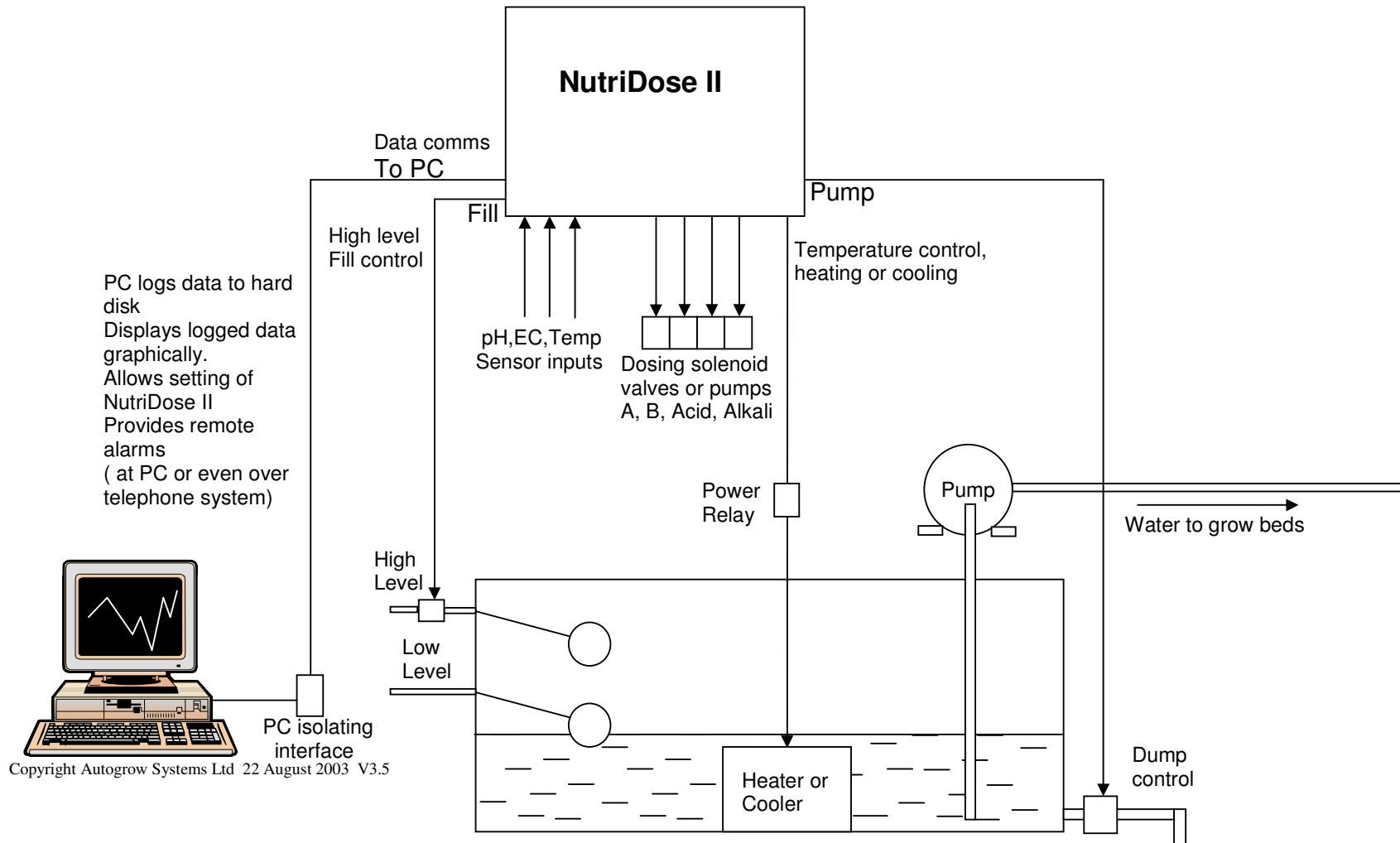

4. Batch-fertigation and Flood-drain systems

Batched irrigation and flood-drain systems are very similar in operation. They both require a tank to be filled (when not irrigating). Then they need a trigger (either from a solar integrator or timer) to dose the tank to the required level followed by an irrigation or flood. Finally they need a time for the system to drain back before refilling. Certainly the flood-drain system can be simplified by installing a float valve low in the main tank so that water is only added at the peak of the flood cycle to make up any deficiency. This allows the fill cycle to be eliminated (set to zero). Otherwise the operation will be identical to a batch irrigation system with a single irrigation zone.

4.1 Overview of batched fertigation

The fertigation function operates by cycling through the following actions:-

- 1) fill the mixing tank for a set time
- 2) wait for trigger (from external solar integrator or internal timer)
- 3) dose and stir the tank until the setpoints are reached (or the maximum stir time is reached)
- 4) irrigate each irrigation zone for the time set.
- 5) Wait for drain back time (can be set to zero for to-waste systems)
- 6) Go back to 1) and refill the tank

When used for fertigation, the controller has an input, which can be used to trigger an irrigation. This input is suitable for connection to a “solar integrator” such as the Autogrow TRS2000 EnviroMinder, which has a built-in solar integrator output. This causes the controller to irrigate after a set amount of sunlight has been received so that the frequency of irrigations automatically increases in sunny weather and decreases when cloudy. The NutriDose-II also has a timed override so that if a solar trigger has not been received within a set amount of time, the unit will force an irrigation. This is a safety feature to protect against a solar integrator failure. An additional setting, specifies whether irrigations are allowed during the night or just during the daytime. If a trigger occurs during the night and the controller is set for “day-time only” operation, the controller will capture the trigger and will irrigate as soon as it enters the next “day” time zone.

If more than two zones are required, a proprietary zone splitter may be used.

However, a far better solution is to use the NutriDose II *i* or NutriDose II *b* which have the ability to be expanded to 30 stations. The NutriDose II *i* (in-line injection) and NutriDose II *b* (batched) allow for very flexible fertigation control and provide a single user interface for all settings and readings.

The Compugrow software allows the user to view and change all controller settings from the remote PC. It also allows the user to trigger events from the PC such as (1) switch dosing ON/OFF, (2) enable/disable zone 1, (3)enable/disable zone 2, (4) Trigger an irrigation sequence, (5) Dose EC and (6) Dose pH.

By using remote access software such as PCAnywhere, it is possible to dial into your supervising PC from anywhere in the world and to view the readings, graphs and settings and to make any changes you wish. Of course this feature can be password protected.

4.2 Install the controller and sample pot

IMPORTANT:

1) **Check that the NutriDose is correctly rated for your power supply voltage**
2) **The NutriDose must be installed (and stored) in a shaded, cool, dry, well ventilated position.** This may be inside a greenhouse which is fully controlled so that the relative humidity does not regularly exceed 90%. For uncontrolled greenhouses, propagation houses, or other high humidity situations it must be installed in a plant room next to the greenhouse which itself is cool, dry, shaded from direct sun and well ventilated. It must never be left in full sunlight or in very hot conditions such as in an automobile. If installed within a greenhouse this normally means that a special shade/drip cover must be provided and shown below. This is important as the surface temperatures of items in a greenhouse in summer, in full sun, may easily exceed 60 deg C (140 deg F). If this is allowed to happen the warranty is voided.

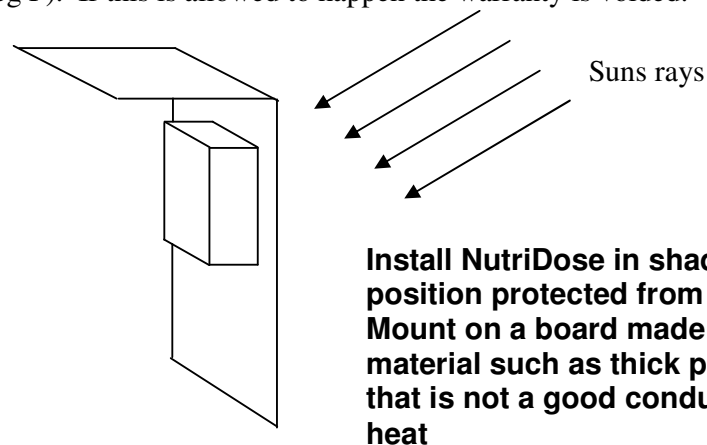

Position the sample pot within close reach of the controller but not where the controller is liable to get splashed if the sample pot overflows etc. Ensure that the leads to the sensors will easily reach between the controller and the sample point.

4.3 Dosing sub-system

Dosing can be done in a number of ways. Where the main tank is underground a simple gravity feed system using solenoid valves may be used. Having the main reservoir tank below ground level has a number of additional advantages such as helping to keep the nutrient water cool during summer as well as saving floor space. In this example, it is assumed that water is supplied under pressure from either the town water supply or from a pressure activated pump which supplies water from a bore (well) or from a storage tank.

It is good practice to either limit the size of the stock tanks or else provide smaller “day” tanks. This is to limit any effect on the plants if all of the stock solution was dumped into the tank due to an equipment failure or incorrect setting. The small day tanks are filled from the larger stock tanks every morning. This can be automated by using small pumps that are operated from a time switch. This also ensures that the stock tanks get stirred every day which will help to avoid stratification of the nutrient in the stock tank.

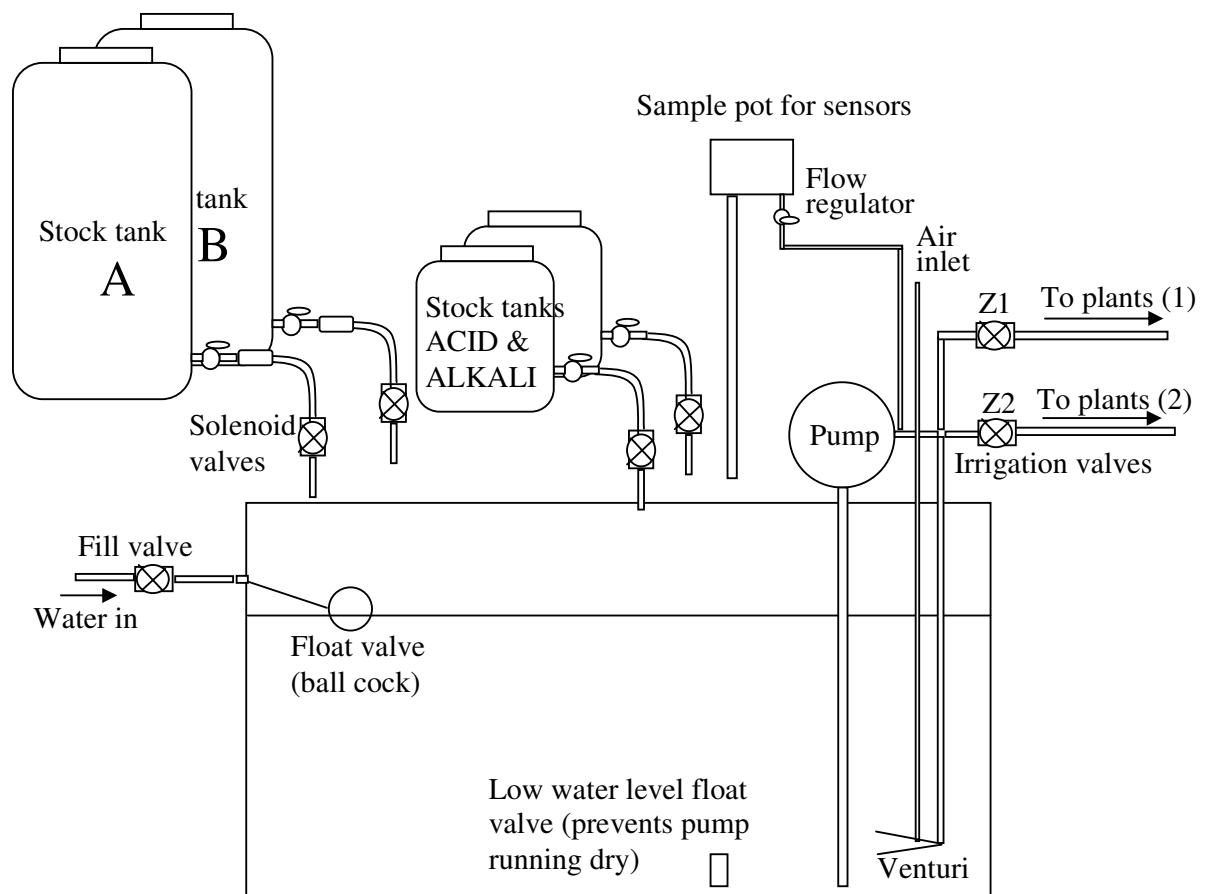

Simple gravity-feed dosing system for 2 zone batched irrigation

To ensure an equal dose from the A and B stock tanks it is important that both filters are clean and that the pipes are of equal length and are not kinked or otherwise restricted. To achieve equal dose sizes it is also important to position both A and B tanks and also the solenoid valves or pumps at the same height.

In situations where the main tank is not below ground level, or if preferred, peristaltic pumps may be used to deliver the nutrient from the stock tanks or day tanks up into main reservoir tank. Many growers prefer the pump option as there is slightly less chance of overdosing in the event of a solenoid becoming jammed open. However, with good quality solenoid valves and regular maintenance this should never happen.

Note also, that during dosing, the pump must keep the nutrient solution flowing through the sample pot and the nutrient water in the main tank must be thoroughly mixed. This can be done by running the main pump as shown in the diagram. Note the use of a venturi to aerate and stir the main tank. This is highly recommended.

4.4 Set selector switch (located under side cover)

Switch ON the “Irrigation”, and the “Main Pump on to stir” switches

Switch OFF switch 8.

The remaining switches can be set to suit your personal preference.

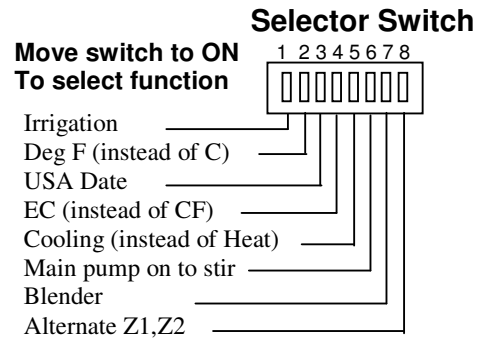

4.5 Connect the EC probe, pH electrode and temperature sensor

The pH electrode simply connects to the BNC connector on the front panel. The EC probe and temperature sensor are connected to connector 1 (the leftmost connector) which is located under the cover on the right hand side of the controller.

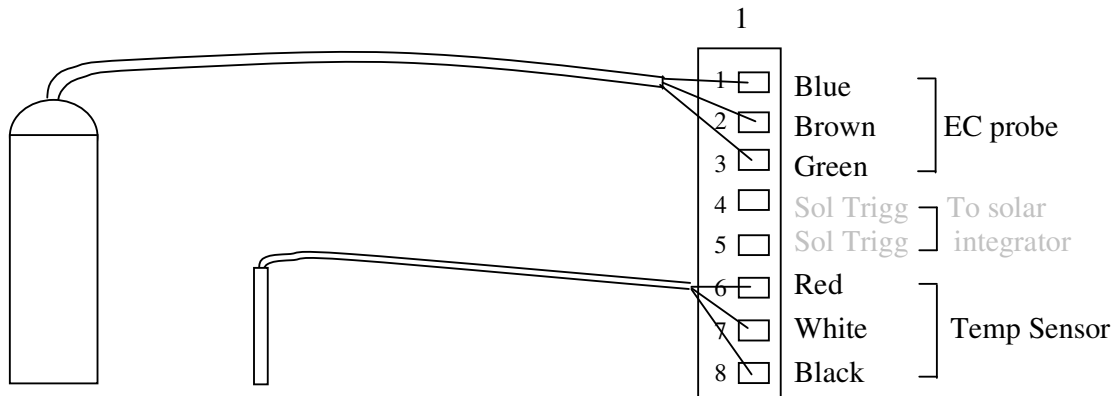

Connection of EC probe and temperature sensor

4.6 Install and connect the dosing solenoids or pumps

24V AC pump relays or solenoid valves

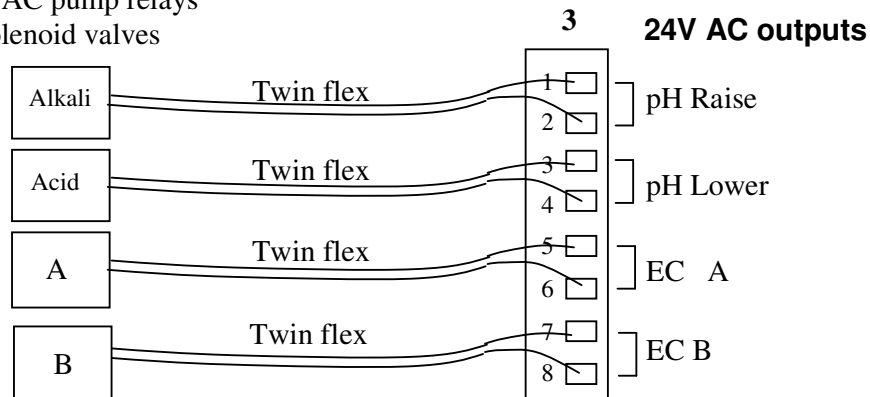

Connection of dosing pump relays or solenoid valves

4.7 Install fill solenoid valve

The fill solenoid valve is installed in series with the float valve of the reservoir tank. The Float valve should be a “full flow” type to allow rapid filling of the tank between irrigations. The fill solenoid valve is connected to connector 4 as shown below.

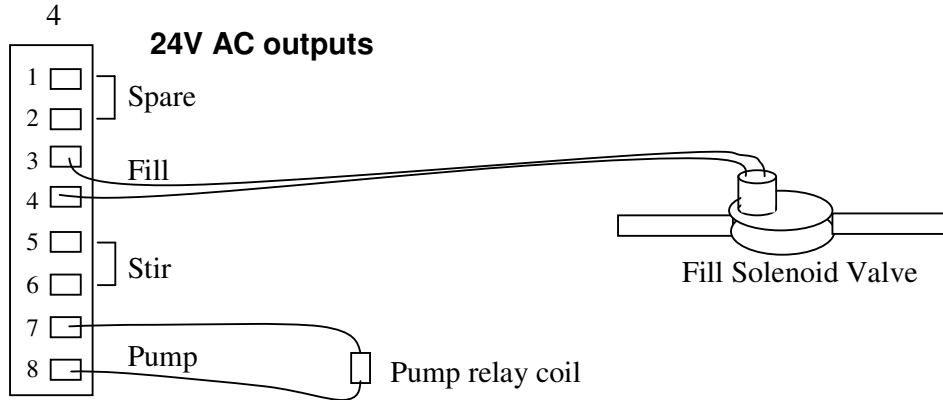

4.8 Install pump relay and wire to controller

The irrigation pump will be mains powered and so you will need to have a power relay fitted by an electrician to supply power to the pump. This relay should have a 24V AC coil which should be connected to connections 7 and 8 of connector 4. (see diagram above). A low-level switch may be connected in series with the coil to stop the pump running when the water in the tank is too low.

It is usual to use the main pump to also stir the tank during dosing. To do this, switch ON the selector switch number 6 and use thin pipe to feed back from the output of the pump through the venturi into the tank. By using thinner pipe, enough pressure will be left to allow irrigation of each zone when the irrigation starts and the zone valves open. If an undersized pump is used then it may be necessary to install a solenoid valve between the pump output and the venturi. This solenoid would be connected to the “stir” output ie connections 5 and 6 of connector 4 (see above). This allows water from the pump to return to the tank via the venturi only during the “stir and dose” cycle and not during the irrigation cycle.

4.9 Install and wire the zone solenoid valves

The zone solenoid valves should also have 24V AC coils. These are connected directly to the Zone 1 and Zone 2 outputs on connector 5

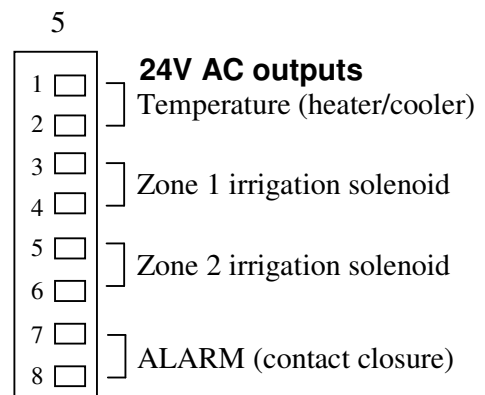

4.10 Connect heater (or cooler) if used

The heater output may be used to operate a nutrient or grow-bed heater. If used for grow-bed heating then the temperature sensor must be placed in the grow-bed whilst for nutrient heating it is normally placed at the bottom of the mixing tank. For continuously recirculating systems it is normally placed in the sample pot. The lead on the sensor may be extended by up to 40metres (120ft) using CAT5 cable. The connections should be made inside a sealed connection box to avoid corrosion. To operate the heater an electrician is needed to wire a mains power relay with a 24V AC coil to the heater output (connections 1 and 2 on Connector 5). When using a heater ensure that selector switch 5 is OFF. For cooling, this switch should be ON.

4.11 PC communications.

Connect the PC data communications cable and install the Compugrow software as shown in section 6

4.12 Set up the dosing set-points.

Set the EC (day time) and EC (night time) – It is common to set the day setpoint a little lower than the night setpoint so that the plants can transpire freely during the heat of the day. Set the pH set point and also specify if pH lower or pH raise is required. Then set the dose times for both EC and pH. The dose time should be sufficient to cause a change in EC (after mixing) of 0.1 to 0.2 mS/cm (1 to 2 CF) and a change in pH of 0.2pH after mixing. The dose interval should be set to a sufficient time for each dose to mix with the water in the tank. If the dose sizes are too small, or if the dose interval is too large, it will take a long time to dose the tank up.

When first installed and set-up it is always a good idea to first fill the stock tanks (A& B fertilizer, acid and alkali) with plain water and observe the dosing operation for a while. This will also give you an opportunity to test for leaks.

Test the dosing outputs by forcing them on and off from the PC “Readings and Settings” tab or from the controller “overrides” sub menu. Also watch them occur automatically.

When everything has been thoroughly checked, fill the A & B drums with the fertiliser mix as directed and stir thoroughly until fully dissolved. In larger systems it is common to use small pumps to circulate and stir the stock tanks to mix them thoroughly. Next fill the acid and alkali tanks as follows:- First add the water to each tank and then add acid and alkali to the water to achieve a concentration of about 2%; stir the mixture as the heavy acid will sink to the bottom. Note that if strong acid/alkali is dosed into the nutrient solution it can cause a localized chemical reaction, which will gradually cause the composition of the nutrient to change.

4.13 Sensor Calibration

When calibrating it is a good idea to disable dosing first but remember to re-enable it when you have finished. To disable it press the mode key to get to the “Overrides” menu item, press enter (up arrow) to enter this sub-menu. The first menu item is dose enable so press the down arrow to set this OFF and then press save.

Calibrate pH

Connect the pH electrode to the BNC plug connector on the front of the unit. Place the electrode in the pH 7 buffer solution and allow it to stand for 10 minutes. Now press the mode button to get to the “calibrate” menu item. Press enter (the up arrow) briefly to enter the calibrate sub-menu. Now press the up or down arrows until the reading is exactly 7.00pH. Press save.

Rinse the electrode in water, then place in pH 4 buffer solution. Wait for 10 minutes and then press the mode button to get to “calibrate” on the menu. Now briefly press enter (up arrow) to enter the submenu and **now press the Mode button again to get to cal pH 4**. Now, press the up and down buttons to get the reading to be exactly 4.00pH and press save. Recheck by placing the pH electrode back into the pH 7 buffer.

Calibrate EC

Clean the face of the EC probe using a clean nylon kitchen scourer such as a “ScotchBrite” together with a mild abrasive cleaner such as “Jif”, rinse in water and place in the EC standard solution. Allow a ten minutes for the temperature compensation to take effect. Now move down to “calibrate”, press enter and then press the mode key again to get to the CAL EC (CF) mode. Now press the up and/or down arrows to get the reading to be exactly the same as the value of the standard solution (usually 27.7 CF or 2.77 EC). Press save.

Note: For highest accuracy, use a standard solution which is as close as possible to your working value and renew the standard solution at regular intervals (3 monthly) .

Remember to re-enable dosing when you have finished calibration.

4.14 Connection to AutoVent, EnviroSensor or solar integrator

The NutriDose II can obtain solar and environmental information for its solar integrator from a number of sources. We will deal with each in turn

AutoVent II or III

Connect the Cat 5 COMMS cable from the AutoVent to COMMS B port on connector 6, pins 3,4 and 5.

In SYSTEM select AUTOVENT 2/3 as your trigger source and in SETTINGS set the solar integration trigger required.

EnviroSensor ES

If using the EnviroSensor for the solar integration function then connect a CAT5 communication cable from the ES COMMS connection to COMM A port on connector 6 pins 6,7 and 8.

In SYSTEM select ENVIRO SENSOR as your trigger source and in SETTINGS set the solar integration trigger required.

Simple solar integrator

If using any other type of solar integrator then connect the trigger output (voltage-less contact closure) from the solar integrator to connector 1 pins 4 & 5.

In SYSTEM select CONTACT CLOSURE as your trigger source.

Example Application

Small “batched” irrigation system or “Flood and Drain system” with solar integrator triggering.

In this application a batch of water is prepared in a large mixing tank (maybe a few hundred or few thousand litres in size) prior to the irrigation. Stirring is vital during the stir/dose cycle and a venturi air injection system as used in a spa pool or jakuzi is recommended for this purpose. The controller then stops filling/stirring and dosing and waits for an irrigation trigger. The trigger can come from either an external solar integrator (calorie counter) or else can be time based from the internal timer. When generated by an external solar integrator the internal timer is used as an override timer. This provides a fail-safe feature by ensuring an irrigation does occur even if the external trigger does not arrive (maybe because a leaf has fallen on the solar sensor or because the weather has been very dull for an extended period).

The NutriDose can be set to irrigate during the day only or during day and night. If set for “day only”, and the irrigation trigger occurs during the night, the trigger is captured and held until the morning when an irrigation will be triggered immediately. In other cases the dose/stir and then the irrigation will start as soon as the trigger arrives. When the irrigation cycle starts, the irrigate output comes on to start the irrigation pump and open the irrigate solenoid valve. The irrigate cycle continues for the time set by the user (in minutes). At the end of the irrigation, the controller will wait for the “drain” period and then refill the tank.

The heater (cooler) output can be used to control the temperature of the grow beds, the root zone or the nutrient in the tank. The temperature is controlled to within 0.5 deg C above and below the setpoint. Obviously, if controlling the grow beds then the sensor must be inserted into the media of the grow bed and the heater (cooler) must directly heat the grow-bed. This is often achieved by the use of water pipes running under the beds.

For a recirculating system, the sensor is usually placed in the sample pot and the heater is usually placed inside the mixing tank. If an electric heater is used a special stainless steel low temperature element should be used

In aeroponic systems, either the nutrient or the root chamber may be heated or cooled. If the root chamber is heated directly then the sensor must be placed in the root chamber.

The temperature sensor cable may be extended by up to 40metres using CAT5 cable. The connection to the sensor should be made inside a waterproof junction box or by using gel filled waterproof connectors.

NutriDose II application suggestions –

2. Two zone batched Irrigation System using internal solar integrator to trigger irrigation

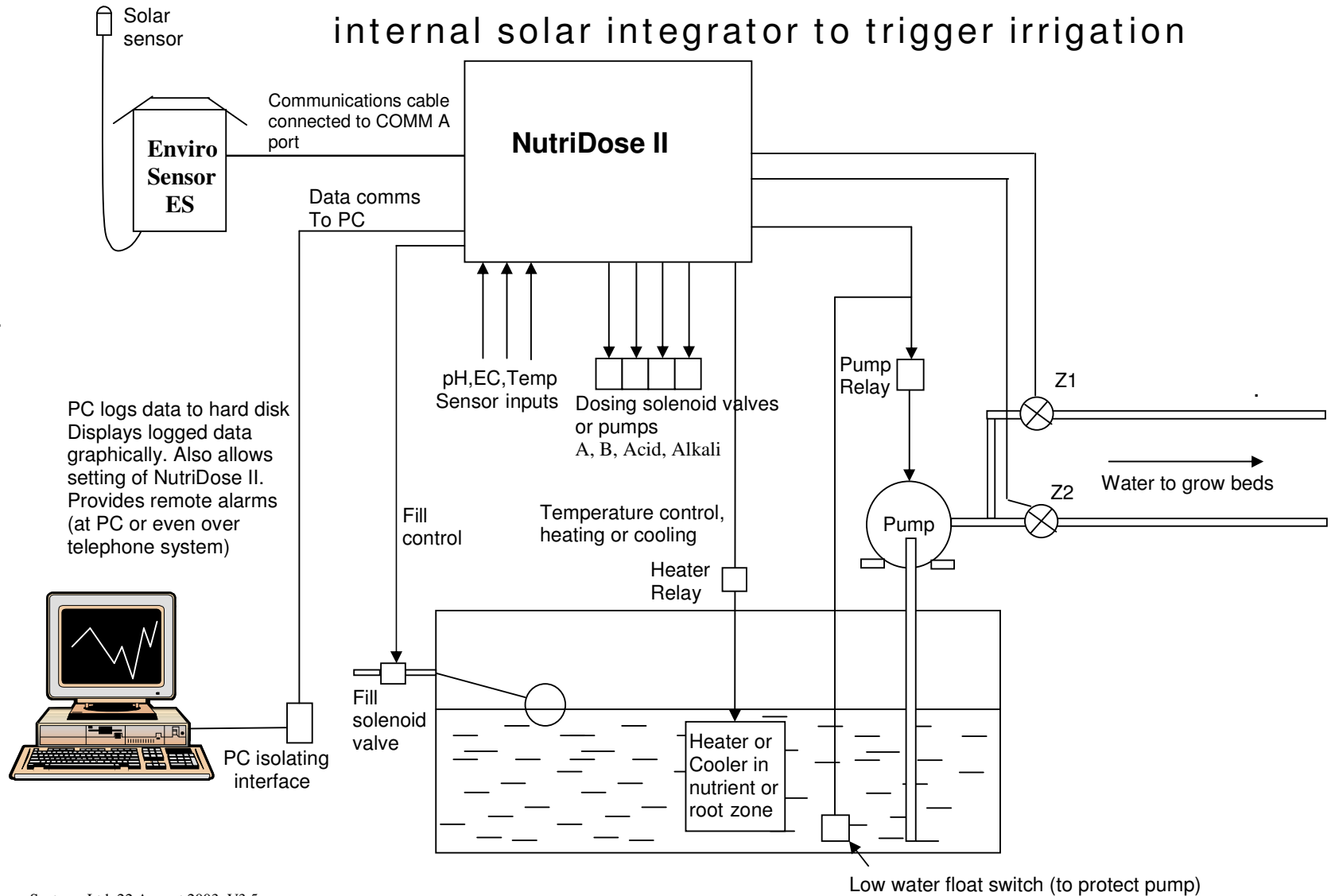

5 Connection diagrams

IMPORTANT:- Before connecting the controller to the mains power supply, check that the voltage sticker on the side of the case matches the voltage for your mains power. This will either be 100-120V or 200-240V.

5.1 Main Circuit Board

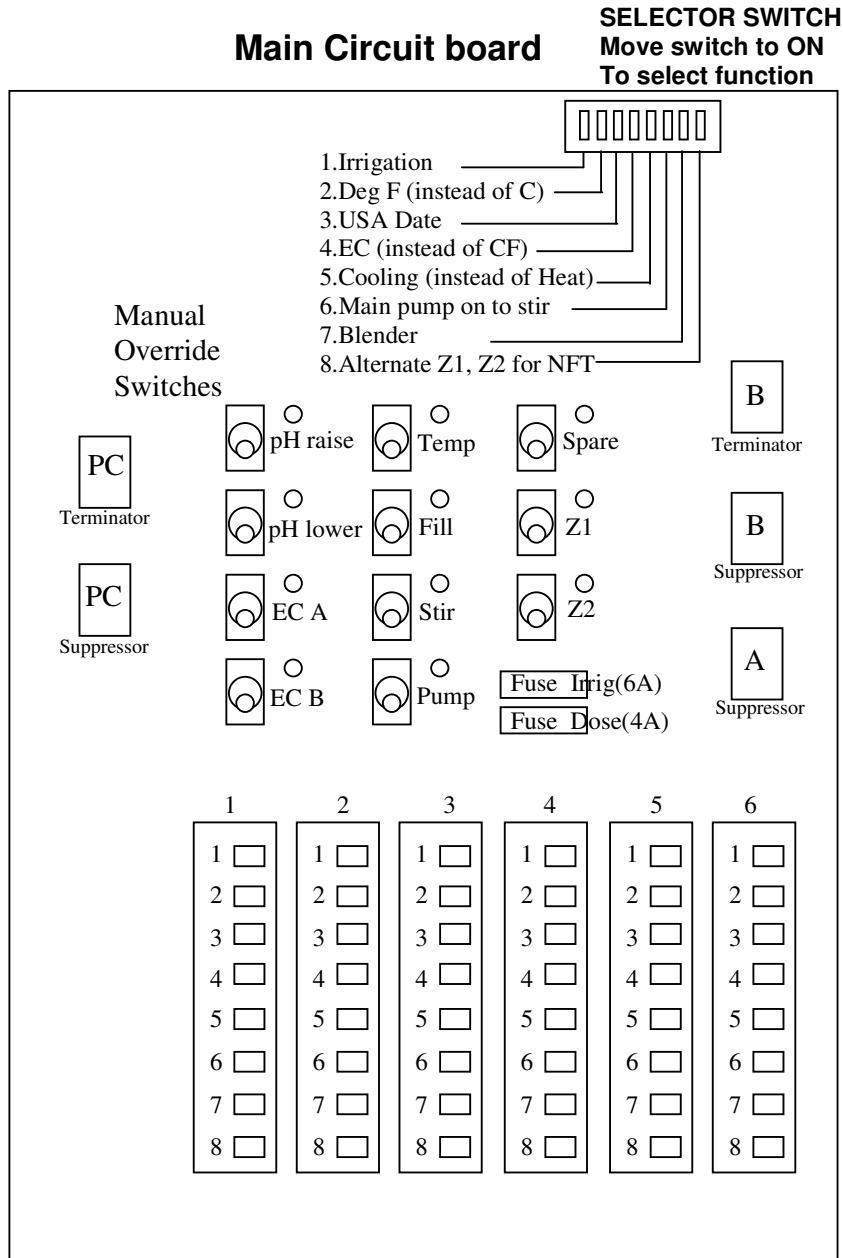

Note that only low voltages (not mains) can be connected to these contacts.

The manual override switches have three positions:-
DOWN=Automatic; CENTRE = OFF; UP = ON

5.2 Connectors

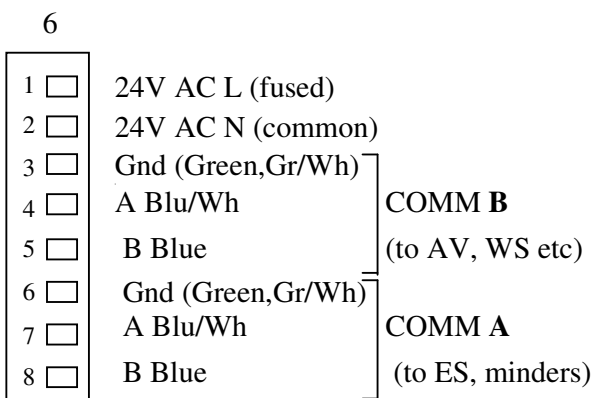
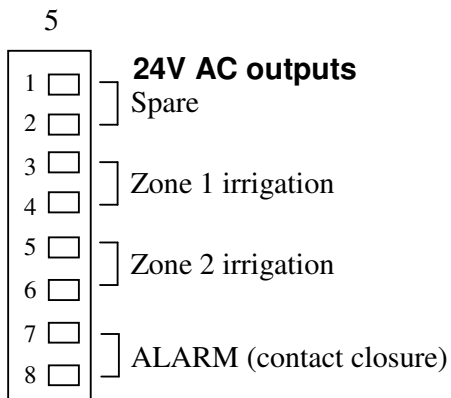
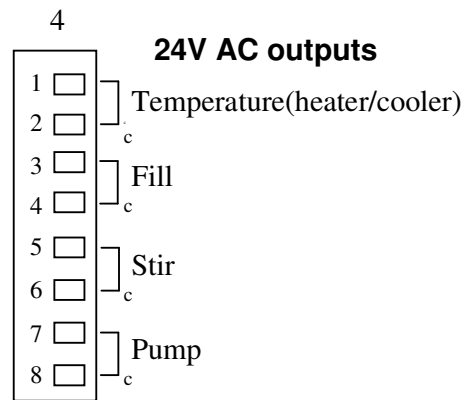
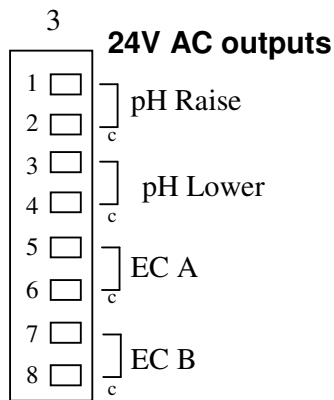
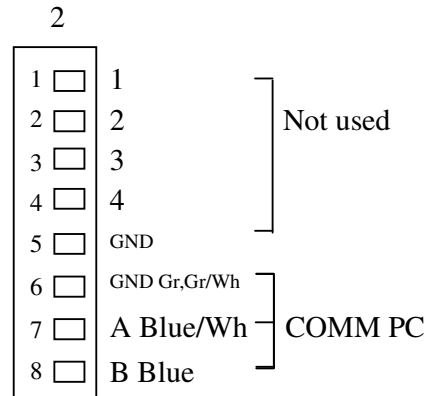
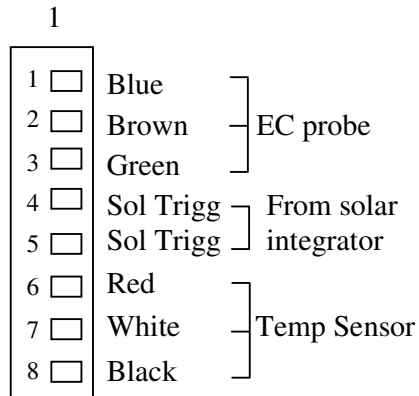

5.3 Connection of Sensors

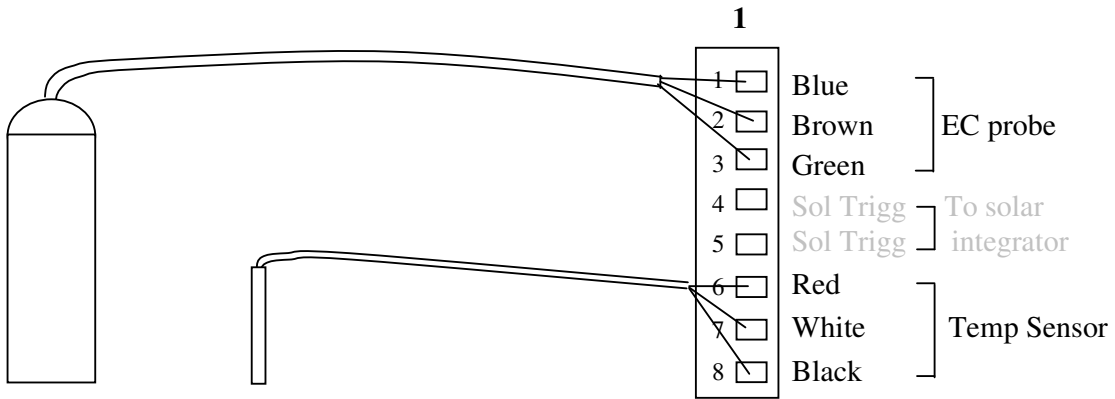

Connection of EC probe and temperature sensor

5.4 Connection of Dosing solenoids or peristaltic pumps

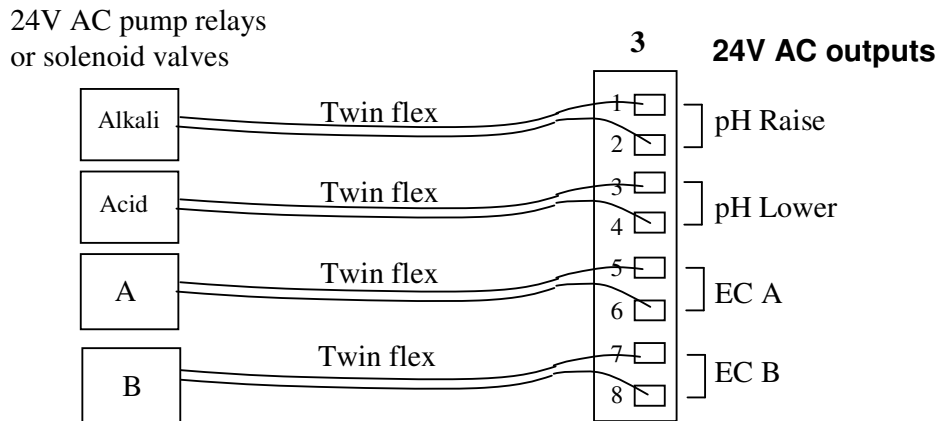

Connection of dosing pump relays or solenoid valves

Where the main tank is above ground, dosing pumps may be used to dose the A & B nutrients and pH adjusters. If mains powered pumps are used, relays must be used to re-power the 24V AC outputs from the NutriDose.

The peristaltic pump unit supplied by Autogrow System is designed to connect directly to these outputs without any additional relays.

5.5 Connection of NutriDose to Enviro Sensor

NutriDose

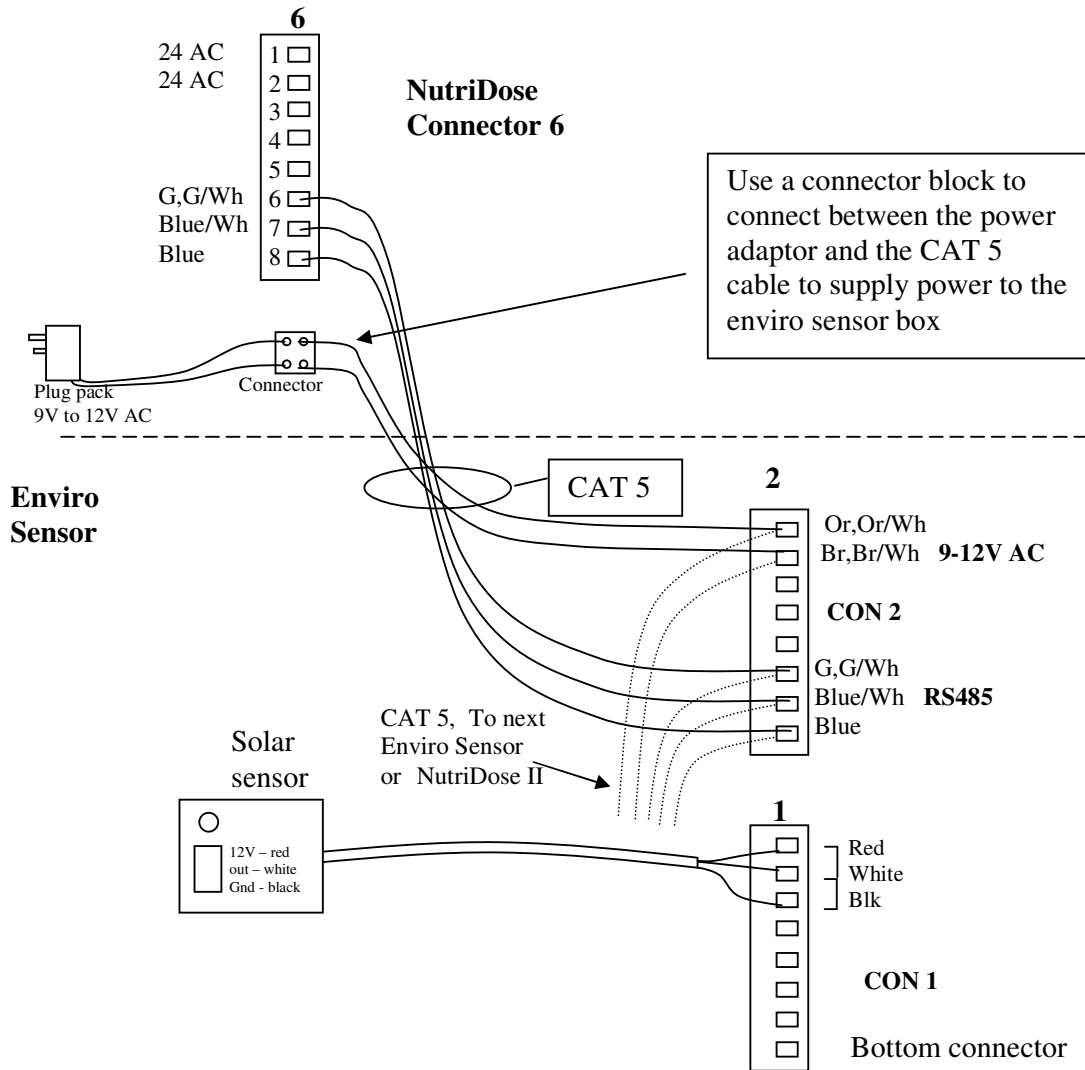

5.6 Data communication cable

Use light coloured (so as not to attract heat) CAT5 stranded computer network cable between the PC interface and the NutriDose and/or monitors. This cable is “looped in” to each controller/monitor in a “daisy chain” fashion. The last monitor (and only the last monitor) in the chain must have a “terminator” fitted. Remember, when adding a further controller/monitor to remove the terminators from any monitor between the PC interface and the last monitor in the chain. See connection diagram below.

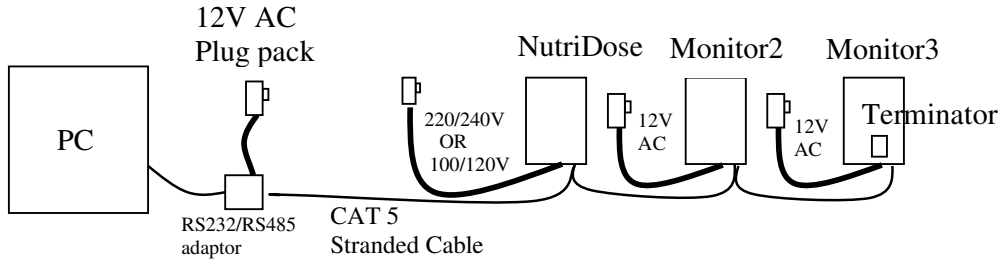

PC connection showing a single terminator at the end of the cable

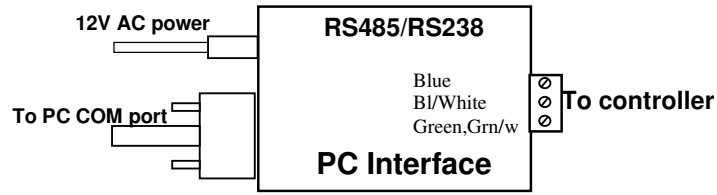

PC interface connections

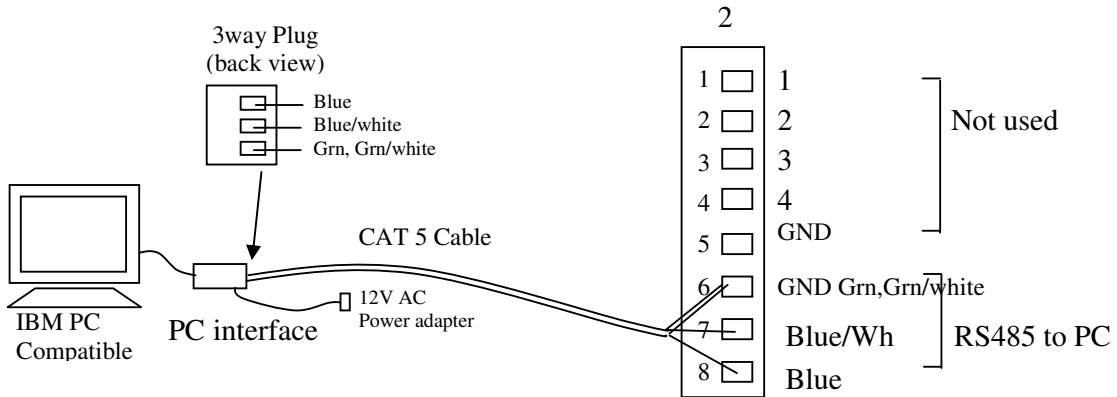

Connection of PC interface to the controller

5.7 Connection to the main pump (Irrigated/ Flood-Drain systems)

As the outputs from the NutriDose are 24V AC they need to be connected to external relay whose contacts will switch the mains power to the pump as follows. **An electrician should be employed to do this work to ensure that it complies with local codes.**

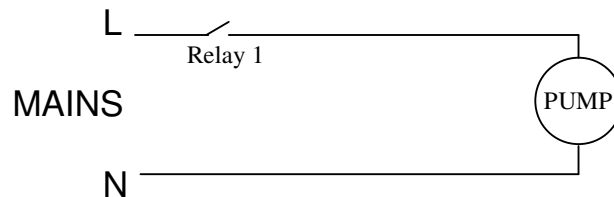
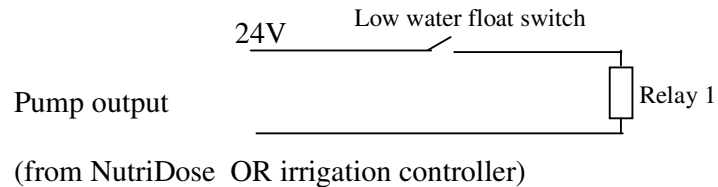

Note the use of a float switch to prevent the pump from running when the water is too low. If this is not fitted the pump could suffer damage if the water runs dry.

Some further application ideas follow at the end of this manual.

5.8 Selection switch settings

A small DIP switch located at the top of the connection board (inside the right hand cover) can be used to select the following alternatives.

- 1) Irrigation or recirculating (ON = Irrigation)
- 2) Temperature in Deg F (ON=F)
- 3) Display date in USA format (ON=USA)
- 4) Display conductivity in EC or CF (ON=EC)
- 5) Temperature control for cooling instead of heating (ON=cooling)
- 6) Main pump on during stir cycle (ON = pump on)
- 7) Blender
- 8) Z1,Z2 alternate

Switch function

When the **irrigation** selection switch is set to ON, the fill, stir and pump outputs will operate automatically in a cyclical fashion. When the controller is first switched on, the fill will operate for the time specified by its setpoint. This must be longer than the actual time to fill the tank. The tank will stop filling when the float valve closes. The controller then waits for a trigger, either from its internal timer or from an external solar integrator or moisture sensor. When a trigger occurs it enters its stir/dose cycle. During this time the controller will be dosing and the stir output will be on. Depending on the dip switch settings, the main pump may also run during this period. The stir output can be used to operate an auxiliary stir pump or else a solenoid that directs the main pump output back into the tank to stir and aerate the nutrient. The EC and pH alarms will be inhibited during this time. The tank will continue stirring and dosing until either both EC and pH setpoints are reached or else the maximum stir time has expired – this time must obviously be long enough for the tank to fully dose up to reach its set points. In an irrigated system the heating will usually be applied to the grow beds rather than the nutrient tank but either method is possible. Switch 7 should be set to ON if this NutriDose gets environmental information from an AutoVent controller. Otherwise it must be left open.

When switch 1 is open (recirculating) and switch 8 is closed, the two zone outputs Z1 and Z2 will be energised alternately (each staying on for the irrigation time set for that zone). This feature may be used in recirculating systems to allow a large area to be irrigated by a small pump by watering each section for 5 or 10 minutes in turn. It can also help when damming of gullies is a problem.

Note that where solar integration is used to trigger irrigations it is normal to use the internal timer as a fail-safe device. The reason for this is that if a solar trigger does not occur (wire broken or leaf fallen on light sensor) in the maximum allowable time then the timer will trigger and hopefully save the plants from wilting. This is why we refer to it as the **Override** timer

The temperature control output of the NutriDose II can be set to operate for heating or cooling. When in heating mode it comes on when the measured temperature drops below the set point by more than 0.5 deg C and goes off when the measured temperature rises above the setpoint by more than 0.5 deg C. When set for cooling it works in exact reverse of this.

The temperature control may be used for any purpose eg heating/cooling the nutrient, the grow bed or the root zone in aeroponics. If not used for control it still provides useful information to the grower.

6 Installation of Compugrow Software on the PC

6.1 The PC Interface.

The RS484/RS232 optically isolated interface box should be installed adjacent to the PC computer. It requires a 12V AC supply. A lead is supplied to connect this to a free DB9 COM port on the back of the PC. A CAT 5 cable (computer network cable) should be used to connect between the PC interface and the controller as shown in the diagram.

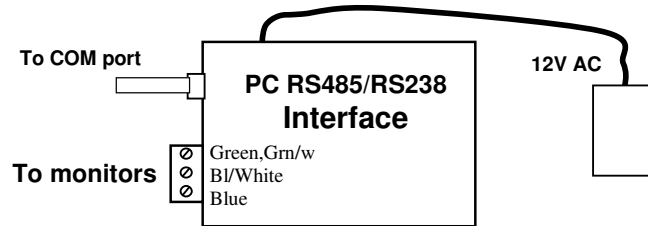

PC interface connections

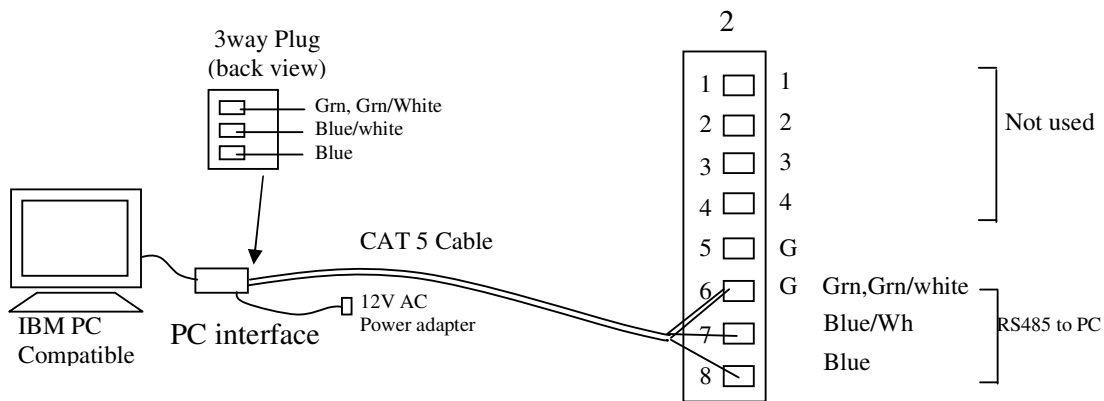

Connection of PC interface to the controller

6.2 Communication addresses.

When the PC requests data from a controller or monitor it first sends the address for that unit. All units connected to the PC must have a different address. The base address for these controllers is 34. At the controller, press the mode key to get to SYSTEM and press enter. Here you will find the "address" number. Press the up or down arrows to change the address to a number that is different to all other units connected to the PC. Typically, set the first controller to 34, the next to 35 and so on. After setting the address, press save to store it in permanent memory. Make a note of the address of each controller/monitor and its type (eg TRS, NutriDoseII etc as you will need to enter this information on the PC.

6.3 Terminator.

The CAT 5, RS485, data cable starts at the PC interface and loops in and out of ALL devices until it reaches the furthest unit. Inside all controllers and monitors will be found a terminator plug. This is a very small circuit board with a small resistor and capacitor on it. These terminators must be removed from all units except for the one at the end of the cable. To locate the terminator, refer to the diagram of the main circuit board in section 5.1.

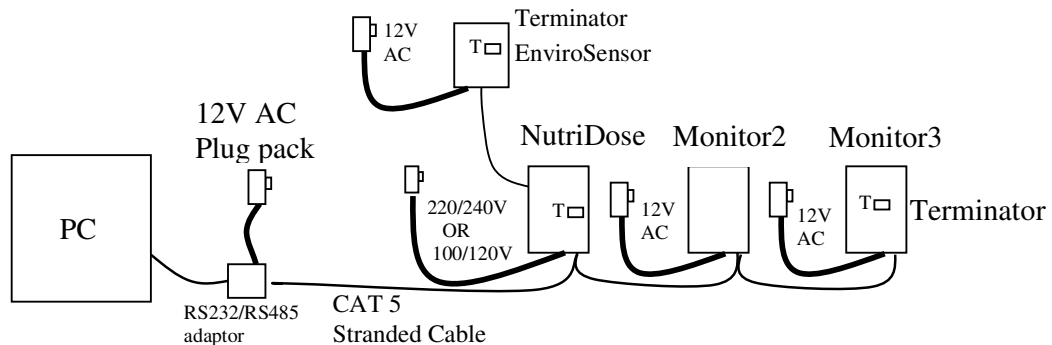

PC connection showing a single terminator at the end of the cable

Note that the secondary cable from the NutriDose to the EnviroSensor also requires a terminator at both ends.

6.4 Installation of the Compugrow software

The CompuGrow software is suitable for use on a PC compatible computer running Windows 95/98/2000/XP. The computer must have a free serial COM port and should be a Pentium or better.

To install the software on your PC, insert the disk in drive A and execute the CompuGrow self-installing program. You will be prompted during installation to select a folder. The default folder is C:\Program Files\Compugrow\... When the program is executed it will create some sub-folders under this folder. Each system (greenhouse) installed will have its own sub-folder where the log files for each of its monitors and controllers is stored. Each file will save the data for the whole current month and the name of the file contains the date (year and month) to make file management easy. Once installed, the program may be executed in the usual way. The first time it is run it is necessary to create a new system and then specify the type and addresses of all controllers and monitors within that system. The help function can be used on-line to assist with this task.

6.5 Configuring the PC software.

Before running the software it is best to install all the controllers and monitors. They should all have their date and time setting checked and each device must have its address set to a unique number. Remember to save the addresses after making any changes and make a note of them as you will need to have them when installing the PC software.

Now, at the PC, run the compugrow.exe application and then set up as follows. When the Compugrow software is first executed the immediate task is to select the required security access level. In order to set the system up, security must either be “disabled” or else you must select ‘advanced’ and enter the advanced password which is ‘consult’. The basic level password is ‘grower’. These are the default passwords which can be changed to anything you desire when in advanced mode. Alternatively, from advanced mode you can disable security by selecting setup/security/disable. Next, select the serial COM port that the RS232/RS485 adaptor is connected to. (Note that the adaptor must be one supplied by Autogrow as it performs some special functions as well as converting the signal levels and providing optical isolation.)

Under “setup” select “add” to add a new system then give the system a name (usually the name of the greenhouse eg lettuce 1) also check the controller box and monitor box if you also have any monitors in the system.

The idea of having different “systems” is that in a large installation where you might have a number of controllers and/or monitors in each greenhouse, it allows you to collect together all of the devices from the one greenhouse as one system so that when you view them they are not muddled in with devices from the other houses. However, if you are only intending say one or two controllers per greenhouse then it is probably more convenient to put all devices into one system.

Once a system has been added, select setup/system setup/configure/<system name> And for each controller and monitor, add the address (as set at the actual controller), select the type of controller, enable it and finally click on “save”. The PC will now try to communicate with the device and values should appear on the “Readings and Settings” tab. If not, try clicking on “refresh” on the main menu bar and observe the message at the bottom, right of the screen. If this says “offline” then the communication link has failed and you will need to recheck that everything is wired correctly and switched on etc. Also recheck all settings. If still not working refer to the fault finding section.

Finally set the logging frequency to be every 5 minutes. The software creates one file for each monitor or controller for each month. Obviously a logging frequency of one minute will create much larger files than if set to 5 minutes and should only be used when you really require that level of detail.

7. Maintenance

Every two weeks:-

Thoroughly clean the EC probe.

Remove the shroud (if fitted), scour the face with a mild bathroom abrasive like Jif (NOT Lemon JIF as this contains oils) on an abrasive nylon pad (ScotchBrite) and then rinse in clean water. DO NOT TOUCH THE PROBE FACE as your perspiration may contain oil.

Replace the shroud fully (so that the face of the probe is central in the round side windows)

Shake off all excess water and place in the CF 27.7 (EC 2.77) standard solution.

Allow to stand for ten minutes before calibrating. The up/down buttons may need to be pressed a number of times (or held down for a while to invoke auto-repeat) to make the displayed values change to the correct reading. Press *save* to store the new calibration.

Check the calibration of the pH electrode:

First rinse in fresh water. Shake gently to displace excess water and place in pH 7 buffer solution. Stand for 10 minutes or longer. Select CAL pH7 mode. Now press the up/down buttons to get the display to read 7.00 and then press **save**. Rinse the electrode in fresh water, shake excess water off and place in pH 4 buffer. Stand for ten minutes or more and then select CAL pH4 mode. Now press the up/down buttons to get the display to read 4.00. Press **save**.

pH electrodes are only warranted for six months but should last for between six months and three years. Never let the tip dry out and when not in use stand in clean water which has a little pH4 buffer added. As pH electrodes age they tend to get slower and slower and also drift when in weak solutions (ie in the nutrient solution) If the pH electrode is looking particularly dirty, you can try standing it in 20% acid for 10 minutes. This will sometimes rejuvenate an aging electrode

The temperature sensor is guaranteed by the manufacturer (Dallas semiconductors) to be accurate to within 0.5 deg C and so any adjustment should be very small. Only calibrate this if you have a **very** accurate reference thermometer. (We have found most sensors to be accurate to within 0.2deg C without any calibration)

8. Faultfinding

Before looking for a fault, ensure all settings (both switches and keypad) are correct

No display : Check power supply is ON and also check fuse on side of cabinet. For the 220V-240V version a 1 Amp fuse is fitted; whereas a 2 Amp fuse is supplied for the 110V-120V model.

EC reading incorrect: **Clean the EC probe** and ensure no air bubbles are trapped beneath it then recalibrate

pH reading wandering and won't calibrate: pH electrode may need to be replaced

No dosing – check dosing fuse

No irrigation outputs – check irrig fuse

No PC communications – PC reports controller to be offline

- address at monitor different to address at PC or two controllers/monitors set with the same address
- cable between monitor and PC broken – try moving the monitor close to the PC to exclude the long cable
- Wires in cable between monitor and PC crossed
- Terminator missing from furthest monitor or terminator present on intermediate monitor. (Only one terminator should be in the system at the furthest monitor from the PC)
- No power to the PC interface unit
- Cable between PC and interface unit disconnected or in wrong COM port of PC
- PC configuration incorrect (IRQ clash or port not installed)
- Wrong COM port selected within CompuGrow software
- Invalid date being received from controller. Reset the time and date and then clear all logs as follows:-
 - (a) Switch off power
 - (b) Hold both mode and save keys pressed in
 - (c) Switch on power and then release the keys

Uploaded data cannot be viewed in the history screen

- Date and/or time on controller or PC incorrect – set time/date and clear logs as described above

Upload of logged data does not stop.

- Clear the logs as described above

9. Warranty

The warranty on the controller, EC sensor and temperature sensor is limited to 2 years – return to factory. Before returning the unit for service you must call Autogrow Systems Ltd for a return authorisation .

pH electrodes, RH sensors and fans carry only a 6 month warranty from their respective manufacturers.

This warranty specifically excludes any parts that have been broken or damaged by water, chemical attack or excessive temperature. In particular, the controller and PC interface must be stored and used in a dry, shaded and well ventilated situation. At no time must the case temperature be allowed to exceed 60 deg C (140 deg F).

This warranty specifically excludes liability for consequential damages or for charges for labour or other expense in making repairs or adjustments, or loss of time or inconvenience.

10 Glossary of Terms and abbreviations

NFT - Nutrient film technique – Nutrient rich water is continuously circulated as a thin film along the bottom of “gullies”. The plant roots spread as a mat over the floor of the gully and absorb nutrient. Often used for growing lettuce and tomatoes

DFT – Deep flow technique - Nutrient rich water is circulated (either continuously or intermittently) through gullies. The water is usually about 60mm deep and in warm climates the gullies are completely insulated by expanded polystyrene sheet material. In many cases the plants are supported in holes through floating polystyrene boards

Flood-and-Drain. In this method the plants are placed in media (usually in pots) on a raised platform or table that is easily drained. The table, which has raised sides, is periodically flooded by a control system. As soon as the desired depth of water is reached, the table is immediately allowed to drain.

Fertigation – An irrigation system that supplies all of the plants food requirements along with the water

Batched Irrigation/Fertigation – In this system a tank (the batch tank) is filled with water and then dosed with fertiliser and pH corrector before being pumped to irrigate the crop

EC – Electrical conductivity measured in mS/cm (milliSiemens per centimetre)

CF – Conductivity Factor. This is similar to EC but the units are smaller so that 1 CF = 0.1mS/cm

PH - The measure of the acidity or alkalinity of a liquid. PH 7 is neutral and most hydroponic growers use a pH of 5.8 which is slightly acidic. If the pH is incorrect some of the fertiliser elements will not be available to the plants.

Solenoid valve – A water control valve that can be switched on and off by an electric current. The solenoid valve has a magnetic solenoid coil whose voltage rating must match the voltage supplied. For irrigation it is common to use 24V AC coils

On-demand dosing or Dosing – The process by which the total salts content and pH of the irrigation water is measured and then automatically corrected by a control system. As the plants use up the fertiliser, the controller automatically adds more.

RS485 – An industrial communications bus (data cable) for transferring information by low cost twisted pair cable (CAT 5 cable) over long distances up to 1.2Km

RS232 – A communications bus (data cable) used on PCs for connecting the PC to a modem etc. Only used for very short distances

Opto Isolated – An industrial technique of passing the electrical data signals between one circuit and another using only light beams. This helps prevent voltage surges in one piece of equipment from passing to another and causing damage.